



CM9881

7.1 Channel DAC & 4 Channel ADC High
Definition Audio Codec

Preliminary Datasheet

Rev. 0.90

Updated: 2019/03/06

Release notes

Revision	Date	Description
0.90	2019/03/06	Initial release

Table of Contents

1.	GENERAL DESCRIPTION	1
2.	FEATURES	2
2.1.	HARDWARE FEATURES	2
2.2.	SYSTEM CONFIGURATION	3
3.	BLOCK DIAGRAM	4
3.1.	ANALOG INPUT/OUTPUT UNIT	5
4.	PIN ASSIGNMENTS	6
5.	PIN DESCRIPTIONS	7
6.	HIGH DEFINITION AUDIO LINK PROTOCOL	10
6.1.	LINK SIGNALS	10
6.1.1.	Link Signal Definitions	11
6.1.2.	Signaling Topology.....	12
6.2.	FRAME COMPOSITION	13
6.2.1.	Outbound Frame – Single SDO.....	13
6.2.2.	Outbound Frame – Multiple SDOs.....	14
6.2.3.	Inbound Frame – Single SDI.....	15
6.2.4.	Inbound Frame – Multiple SDIs.....	16
6.2.5.	Variable Sample Rates	16
6.3.	RESET AND INITIALIZATION	19
6.3.1.	Link Reset	19
6.3.2.	Codec Reset.....	20
6.3.3.	Codec Initialization Sequence	21
6.4.	VERB AND RESPONSE FORMAT	21
6.4.1.	Command Verb Format.....	21
6.4.2.	Response Format.....	24
6.5.	POWER MANAGEMENT.....	24
6.5.1.	System Power State Definitions.....	24
6.5.2.	Power Controls in NID 01h.....	25
6.5.3.	Powered Down Conditions.....	25
7.	SUPPORTED VERBS AND PARAMETERS	26
7.1.	VERB – GET PARAMETERS (VERB ID=F00H).....	26
7.1.1.	Parameter – Vendor ID (Verb ID=F00h, Parameter ID=00h).....	26
7.1.2.	Parameter – Revision ID (Verb ID=F00h, Parameter ID=02h).....	26
7.1.3.	Parameter – Subordinate Node Count (Verb ID=F00h, Parameter ID=04h).....	26
7.1.4.	Parameter – Function Group Type (Verb ID=F00h, Parameter ID=05h).....	27
7.1.5.	Parameter – Audio Function Capabilities (Verb ID=F00h, Parameter ID=08h).....	28
7.1.6.	Parameter – Audio Widget Capabilities (Verb ID=F00h, Parameter ID=09h).....	28
7.1.7.	Parameter – Supported PCM Size, Rates (Verb ID=F00h, Parameter ID=0Ah).....	29
7.1.8.	Parameter – Supported Stream Formats (Verb ID=F00h, Parameter ID=0Bh).....	30
7.1.9.	Parameter – Pin Capabilities (Verb ID=F00h, Parameter ID=0Ch).....	30
7.1.10.	Parameter – Amplifier Capabilities (Verb ID=F00h, Input Amplifier Parameter ID=0Dh).....	31
7.1.11.	Parameter – Amplifier Capabilities (Verb ID=F00h, Output Amplifier Parameter ID=12h).....	31
7.1.12.	Parameter – Connect List Length (Verb ID=F00h, Parameter ID=0Eh).....	32
7.1.13.	Parameter – Supported Power States (Verb ID=F00h, Parameter ID=0Fh).....	32

7.1.14.	Parameter – Processing Capabilities (Verb ID=F00h, Parameter ID=10h).....	33
7.1.15.	Parameter – GPIO Capabilities (Verb ID=F00h, Parameter ID=11h).....	33
7.1.16.	Parameter – Volume Knob Capabilities (Verb ID=F00h, Parameter ID=13h).....	33
7.2.	VERB – GET CONNECTION SELECT CONTROL (VERB ID=F01H).....	34
7.3.	VERB – SET CONNECTION SELECT (VERB ID=701H).....	34
7.4.	VERB – GET CONNECTION LIST ENTRY (VERB ID=F02H).....	34
7.5.	VERB – GET PROCESSING STATE (VERB ID=F03H).....	41
7.6.	VERB – SET PROCESSING STATE (VERB ID=703H).....	41
7.7.	VERB – GET COEFFICIENT INDEX (VERB ID=DH).....	41
7.8.	VERB – SET COEFFICIENT INDEX (VERB ID=5H).....	42
7.9.	VERB – GET PROCESSING COEFFICIENT (VERB ID=CH).....	42
7.10.	VERB – SET PROCESSING COEFFICIENT (VERB ID=4H).....	42
7.11.	VERB – GET AMPLIFIER GAIN (VERB ID=BH).....	43
7.12.	VERB – SET AMPLIFIER GAIN (VERB ID=3H).....	45
7.13.	VERB – GET CONVERTER FORMAT (VERB ID=AH).....	46
7.14.	VERB – SET CONVERTER FORMAT (VERB ID=2H).....	47
7.15.	VERB – GET POWER STATE (VERB ID=F05H).....	48
7.16.	VERB – SET POWER STATE (VERB ID=705H).....	48
7.17.	VERB – GET CONVERTER STREAM, CHANNEL (VERB ID=F06H).....	49
7.18.	VERB – SET CONVERTER STREAM, CHANNEL (VERB ID=706H).....	49
7.19.	VERB – GET PIN WIDGET CONTROL (VERB ID=F07H).....	50
7.20.	VERB – SET PIN WIDGET CONTROL (VERB ID=707H).....	51
7.21.	VERB – GET UNSOLICITED RESPONSE CONTROL (VERB ID=F08H).....	51
7.22.	VERB – SET UNSOLICITED RESPONSE CONTROL (VERB ID=708H).....	52
7.23.	VERB – GET PIN SENSE (VERB ID=F09H).....	52
7.24.	VERB – EXECUTE PIN SENSE (VERB ID=709H).....	53
7.25.	VERB – GET VOLUME KNOB WIDGET (VERB ID=F0FH).....	53
7.26.	VERB – SET VOLUME KNOB WIDGET (VERB ID=70FH).....	54
7.27.	VERB – GET CONFIGURATION DEFAULT (VERB ID=F1CH).....	55
7.28.	VERB – SET CONFIGURATION DEFAULT BYTES 0, 1, 2, 3 (VERB ID=71CH/71DH/71EH/71FH FOR BYTES 0, 1, 2, 3).....	57
7.29.	VERB – GET BEEP GENERATOR (VERB ID=F0AH).....	57
7.30.	VERB – SET BEEP GENERATOR (VERB ID=70AH).....	58
7.31.	VERB – GET GPIO DATA (VERB ID=F15H).....	58
7.32.	VERB – SET GPIO DATA (VERB ID=715H).....	59
7.33.	VERB – GET GPIO ENABLE MASK (VERB ID=F16H).....	59
7.34.	VERB – SET GPIO ENABLE MASK (VERB ID=716H).....	60
7.35.	VERB – GET GPIO DIRECTION (VERB ID=F17H).....	60
7.36.	VERB – SET GPIO DIRECTION (VERB ID=717H).....	61
7.37.	VERB – GET GPIO UNSOLICITED RESPONSE ENABLE MASK (VERB ID=F19H).....	61
7.38.	VERB – SET GPIO UNSOLICITED RESPONSE ENABLE MASK (VERB ID=719H).....	62
7.39.	VERB – FUNCTION RESET (VERB ID=7FFH).....	62
7.40.	VERB – GET DIGITAL CONVERTER CONTROL 1, 2, 3, 4 (VERB ID=F0DH, F0EH, F3EH, F3FH).....	63
7.41.	VERB – SET DIGITAL CONVERTER CONTROL 1, 2, 3, 4 (VERB ID=70DH, 70EH, 73EH, 73FH).....	64
7.42.	VERB – GET SUBSYSTEM ID [31:0] (VERB ID=F20H/F21H/F22H/F23H).....	65
7.43.	VERB – SET SUBSYSTEM ID [31:0] (VERB ID=723H FOR [31:24], 722H FOR [23:16], 721H FOR [15:8], 720H FOR [7:0]) 66	66
7.44.	VERB – GET EAPD CONTROL (VERB ID=F0CH FOR GET).....	66
7.45.	VERB – SET EAPD CONTROL (VERB ID=70CH FOR SET).....	67
8.	ELECTRICAL CHARACTERISTICS	68
8.1.	DC CHARACTERISTICS.....	68
8.1.1.	Absolute Maximum Ratings.....	68
8.1.2.	Threshold Voltage.....	68
8.1.3.	Digital Filter Characteristics.....	69
8.1.4.	SPDIF Output Characteristics.....	69

8.2.	AC CHARACTERISTICS	70
8.2.1.	<i>Link Reset and Initialization Timing</i>	70
8.2.2.	<i>Link Timing Parameters at the Codec</i>	71
8.2.3.	<i>SPDIF Output and Input Timing</i>	72
8.2.4.	<i>Test Mode</i>	72
8.3.	ANALOG PERFORMANCE	73
9.	APPLICATION SUPPLEMENTS	74
9.1.	STANDBY MODE	74
10.	MECHANICAL DIMENSIONS	75
11.	ORDERING INFORMATION	76

List of Tables

TABLE 1.	PIN DESCRIPTIONS	7
TABLE 2.	LINK SIGNAL DEFINITIONS	11
TABLE 3.	HDA SIGNAL DEFINITIONS	11
TABLE 4.	DEFINED SAMPLE RATE AND TRANSMISSION RATE.....	17
TABLE 5.	48kHz VARIABLE RATE OF DELIVERY TIMING	17
TABLE 6.	44.1kHz VARIABLE RATE OF DELIVERY TIMING	18
TABLE 7.	40-BIT COMMANDS IN 4-BIT VERB FORMAT	21
TABLE 8.	40-BIT COMMANDS IN 12-BIT VERB FORMAT	21
TABLE 9.	VERBS SUPPORTED BY THE CM9881 (Y=SUPPORTED).....	22
TABLE 10.	PARAMETERS IN THE CM9881 (Y=SUPPORTED).....	23
TABLE 11.	SOLICITED RESPONSE FORMAT	24
TABLE 12.	UNSOLICITED RESPONSE FORMAT	24
TABLE 13.	SYSTEM POWER STATE DEFINITIONS	24
TABLE 14.	POWER CONTROLS IN NID 01H.....	25
TABLE 15.	POWERED DOWN CONDITIONS.....	25
TABLE 16.	VERB – GET PARAMETERS (VERB ID=F00H).....	26
TABLE 17.	PARAMETER – VENDOR ID (VERB ID=F00H, PARAMETER ID=00H).....	26
TABLE 18.	PARAMETER – REVISION ID (VERB ID=F00H, PARAMETER ID=02H).....	26
TABLE 19.	PARAMETER – SUBORDINATE NODE COUNT (VERB ID=F00H, PARAMETER ID=04H).....	27
TABLE 20.	PARAMETER – FUNCTION GROUP TYPE (VERB ID=F00H, PARAMETER ID=05H)	27
TABLE 21.	PARAMETER – AUDIO FUNCTION CAPABILITIES (VERB ID=F00H, PARAMETER ID=08H).....	28
TABLE 22.	PARAMETER – AUDIO WIDGET CAPABILITIES (VERB ID=F00H, PARAMETER ID=09H).....	28
TABLE 23.	PARAMETER – SUPPORTED PCM SIZE, RATES (VERB ID=F00H, PARAMETER ID=0AH)	29
TABLE 24.	PARAMETER – SUPPORTED STREAM FORMATS (VERB ID=F00H, PARAMETER ID=0BH).....	30
TABLE 25.	PARAMETER – PIN CAPABILITIES (VERB ID=F00H, PARAMETER ID=0CH)	30
TABLE 26.	PARAMETER – AMPLIFIER CAPABILITIES (VERB ID=F00H, INPUT AMPLIFIER PARAMETER ID=0DH).....	31
TABLE 27.	PARAMETER – AMPLIFIER CAPABILITIES (VERB ID=F00H, OUTPUT AMPLIFIER PARAMETER ID=12H)	31
TABLE 28.	PARAMETER – CONNECT LIST LENGTH (VERB ID=F00H, PARAMETER ID=0EH)	32
TABLE 29.	PARAMETER – SUPPORTED POWER STATES (VERB ID=F00H, PARAMETER ID=0FH)	32
TABLE 30.	PARAMETER – PROCESSING CAPABILITIES (VERB ID=F00H, PARAMETER ID=10H).....	33
TABLE 31.	PARAMETER – GPIO CAPABILITIES (VERB ID=F00H, PARAMETER ID=11H)	33
TABLE 32.	PARAMETER – VOLUME KNOB CAPABILITIES (VERB ID=F00H, PARAMETER ID=13H).....	33
TABLE 33.	VERB – GET CONNECTION SELECT CONTROL (VERB ID=F01H).....	34
TABLE 34.	VERB – SET CONNECTION SELECT (VERB ID=701H).....	34
TABLE 35.	VERB – GET CONNECTION LIST ENTRY (VERB ID=F02H)	34
TABLE 36.	VERB – GET PROCESSING STATE (VERB ID=F03H)	41
TABLE 37.	VERB – SET PROCESSING STATE (VERB ID=703H)	41
TABLE 38.	VERB – GET COEFFICIENT INDEX (VERB ID=DH).....	41
TABLE 39.	VERB – SET COEFFICIENT INDEX (VERB ID=5H)	42
TABLE 40.	VERB – GET PROCESSING COEFFICIENT (VERB ID=CH)	42
TABLE 41.	VERB – SET PROCESSING COEFFICIENT (VERB ID=4H).....	42
TABLE 42.	VERB – GET AMPLIFIER GAIN (VERB ID=BH).....	43
TABLE 43.	VERB – SET AMPLIFIER GAIN (VERB ID=3H).....	45
TABLE 44.	VERB – GET CONVERTER FORMAT (VERB ID=AH).....	46
TABLE 45.	VERB – SET CONVERTER FORMAT (VERB ID=2H)	47
TABLE 46.	VERB – GET POWER STATE (VERB ID=F05H).....	48
TABLE 47.	VERB – SET POWER STATE (VERB ID=705H)	48
TABLE 48.	VERB – GET CONVERTER STREAM, CHANNEL (VERB ID=F06H)	49
TABLE 49.	VERB – SET CONVERTER STREAM, CHANNEL (VERB ID=706H).....	49
TABLE 50.	VERB – GET PIN WIDGET CONTROL (VERB ID=F07H)	50
TABLE 51.	VERB – SET PIN WIDGET CONTROL (VERB ID=707H)	51

TABLE 52. VERB – GET UNSOLICITED RESPONSE CONTROL (VERB ID=F08H)	51
TABLE 53. VERB – SET UNSOLICITED RESPONSE CONTROL (VERB ID=708H)	52
TABLE 54. VERB – GET PIN SENSE (VERB ID=F09H).....	52
TABLE 55. VERB – EXECUTE PIN SENSE (VERB ID=709H).....	53
TABLE 56. VERB – GET VOLUME KNOB (VERB ID=F0FH).....	53
TABLE 57. VERB – SET VOLUME KNOB (VERB ID=70FH)	54
TABLE 58. VERB – GET CONFIGURATION DEFAULT (VERB ID=F1CH)	55
TABLE 59. DEFAULT CONFIGURATION IN CHIP (14H~19H)	56
TABLE 60. DEFAULT CONFIGURATION IN CHIP (1AH~21H)	56
TABLE 61. VERB – SET CONFIGURATION DEFAULT BYTES 0, 1, 2, 3	57
TABLE 62. VERB – GET BEEP GENERATOR (VERB ID= F0AH)	57
TABLE 63. VERB – SET BEEP GENERATOR (VERB ID= 70AH)	58
TABLE 64. VERB – GET GPIO DATA (VERB ID= F15H).....	58
TABLE 65. VERB – SET GPIO DATA (VERB ID= 715H).....	59
TABLE 66. VERB – GET GPIO ENABLE MASK (VERB ID= F16H).....	59
TABLE 67. VERB – SET GPIO ENABLE MASK (VERB ID=716H)	60
TABLE 68. VERB – GET GPIO DIRECTION (VERB ID=F17H).....	60
TABLE 69. VERB – SET GPIO DIRECTION (VERB ID=717H)	61
TABLE 70. VERB – GET GPIO UNSOLICITED RESPONSE ENABLE MASK (VERB ID=F19H).....	61
TABLE 71. VERB – SET GPIO UNSOLICITED RESPONSE ENABLE MASK (VERB ID=719H).....	62
TABLE 72. VERB – FUNCTION RESET (VERB ID=7FFH)	62
TABLE 73. VERB – GET DIGITAL CONVERTER CONTROL 1, 2, 3, 4 (VERB ID=F0DH, F0EH, F3EH, F3FH)	63
TABLE 74. VERB – SET DIGITAL CONVERTER CONTROL 1, 2, 3, 4 (VERB ID=70DH, 70EH, 73EH, 73FH).....	64
TABLE 75. VERB – GET SUBSYSTEM ID [31:0] (VERB ID=F20H/F21H/F22H/F23H).....	65
TABLE 76. VERB – SET SUBSYSTEM ID [31:0] (VERB ID=723H FOR [31:24], 722H FOR [23:16], 721H FOR [15:8], 720H FOR [7:0])	66
TABLE 77. VERB – GET EAPD CONTROL (VERB ID=F0CH)	66
TABLE 78. VERB – SET EAPD CONTROL (VERB ID=70CH FOR SET)	67
TABLE 79. ABSOLUTE MAXIMUM RATINGS	68
TABLE 80. THRESHOLD VOLTAGE	68
TABLE 81. DIGITAL FILTER CHARACTERISTICS	69
TABLE 82. SPDIF OUTPUT CHARACTERISTICS.....	69
TABLE 83. LINK RESET AND INITIALIZATION TIMING.....	70
TABLE 84. LINK TIMING PARAMETERS AT THE CODEC	71
TABLE 85. SPDIF OUTPUT AND INPUT TIMING	72
TABLE 86. ANALOG PERFORMANCE.....	73
TABLE 87. STANDBY MODE	74
TABLE 88. ORDERING INFORMATION	76

List of Figures

FIGURE 1. SYSTEM CONNECTION FOR 6+2 CHANNELS	3
FIGURE 1. BLOCK DIAGRAM	5
FIGURE 2. ANALOG INPUT/OUTPUT UNIT.....	5
FIGURE 3. PIN ASSIGNMENTS	6
FIGURE 4. HDA LINK PROTOCOL.....	10
FIGURE 5. BIT TIMING.....	11
FIGURE 6. SIGNALING TOPOLOGY	12
FIGURE 7. SDO OUTBOUND FRAME.....	13
FIGURE 8. SDO STREAM TAG IS INDICATED IN SYNC.....	14
FIGURE 9. STRIPED STREAM ON MULTIPLE SDOS.....	14
FIGURE 10. SDI INBOUND STREAM	15
FIGURE 11. SDI STREAM TAG AND DATA	15
FIGURE 12. CODEC TRANSMITS DATA OVER MULTIPLE SDIS.....	16
FIGURE 13. LINK RESET TIMING.....	20
FIGURE 14. CODEC INITIALIZATION SEQUENCE.....	21
FIGURE 15. LINK RESET AND INITIALIZATION TIMING	70
FIGURE 16. LINK SIGNALS TIMING	71
FIGURE 17. OUTPUT AND INPUT TIMING.....	72

1. General Description

The CM9881 provides eight DAC channels that simultaneously support 7.1-channel sound playback and two integrated stereo ADCs.

Analog I/O (port-A/port-B/port-C/port-D/port-E/port-G) are stereo input and output re-tasking. Headphone amplifiers are also integrated at two analog output ports (port-C/port-D). Port-H and port-I support direct earphone drive, with no requirement for a DC capacitor.

Support for output with up to 192KHz sample rate offers easy connection of PCs to consumer electronic products. The CM9822A also supports 16/20/24-bit S/PDIF output to offer easy connection of PCs to high quality consumer electronic products such as digital decoders and speakers.

The CM9881 supports not only host audio from the Intel chipsets, but also from any other HDA compatible audio controller.

2. Features

2.1. Hardware Features

- DACs with 97dB SNR (A-weighting), ADCs with 92dB SNR (A-weighting)
- Four stereo DACs support 16/20/24-bit PCM format for 7.1 channel sound playback
- Two stereo ADCs support 16/20/24-bit PCM format, multiple stereo recording
- All DACs supports 44.1k/48k/96k/192kHz sample rate
- All ADCs supports 44.1k/48k/96k/192kHz sample rate
- 16/20/24-bit SPDIF-OUT supports 32k/44.1k/48k/88.2k/96k/192kHz sample rate
- Analog jacks (port-A/port-B/port-C/port-D/port-E/port-G) are stereo input and output re-tasking
- Port-D/C/H/I built-in headphone amplifiers
- Port-H and port-I support direct drive earphone, with no need for a DC capacitor
- Port-B/C/E/F with software selectable boost gain (+10/+20/+30dB) for analog microphone input
- Supports external PCBEEP input and built-in digital BEEP generator
- Software selectable 2.5V/3.2V/4.0V VREFOUT
- Four jack detection pins; each designed to detect 2 jacks
- Supports legacy analog mixer architecture
- One GPIO (General Purpose Input and Output) for customized applications.
- Supports anti-pop mode when analog power LDO-IN is on and digital power is off
- 0.75dB per step output volume and input volume control
- Supports 3.3V digital core power, 1.5V or 3.3V digital I/O power for HD Audio link, and 5.0V analog power
- Intel low power ECR compliant, and power status control for each analog/digital converter and pin widget
- Built-in Low-dropout (LDO) regulator for analog circuit with short current function
- Ultra low power consumption in anti-pop mode
- 48-pin LQFP 'Green' package

2.2. System Configuration

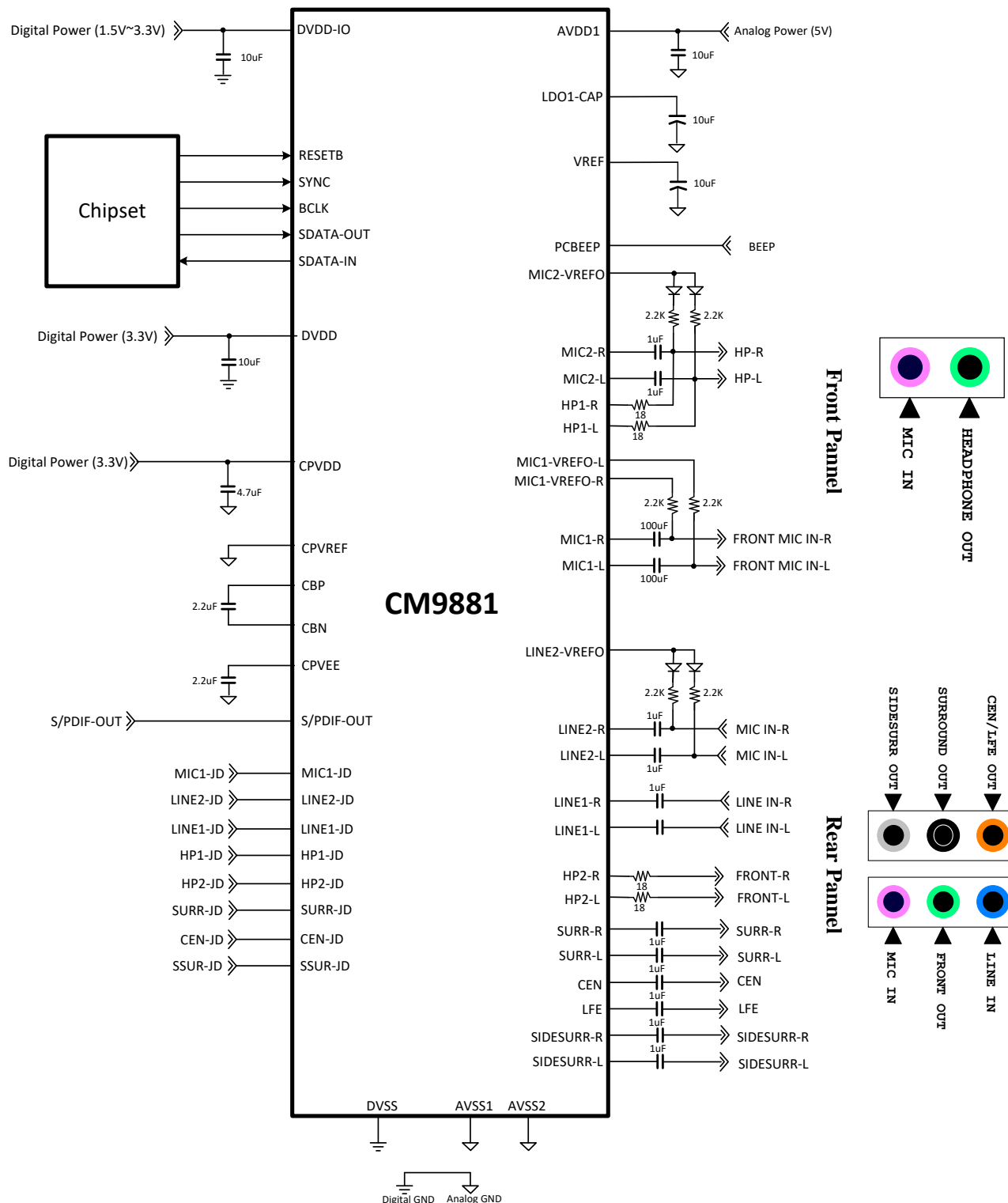

Figure 1. System connection for 6+2 channels

3. Block Diagram

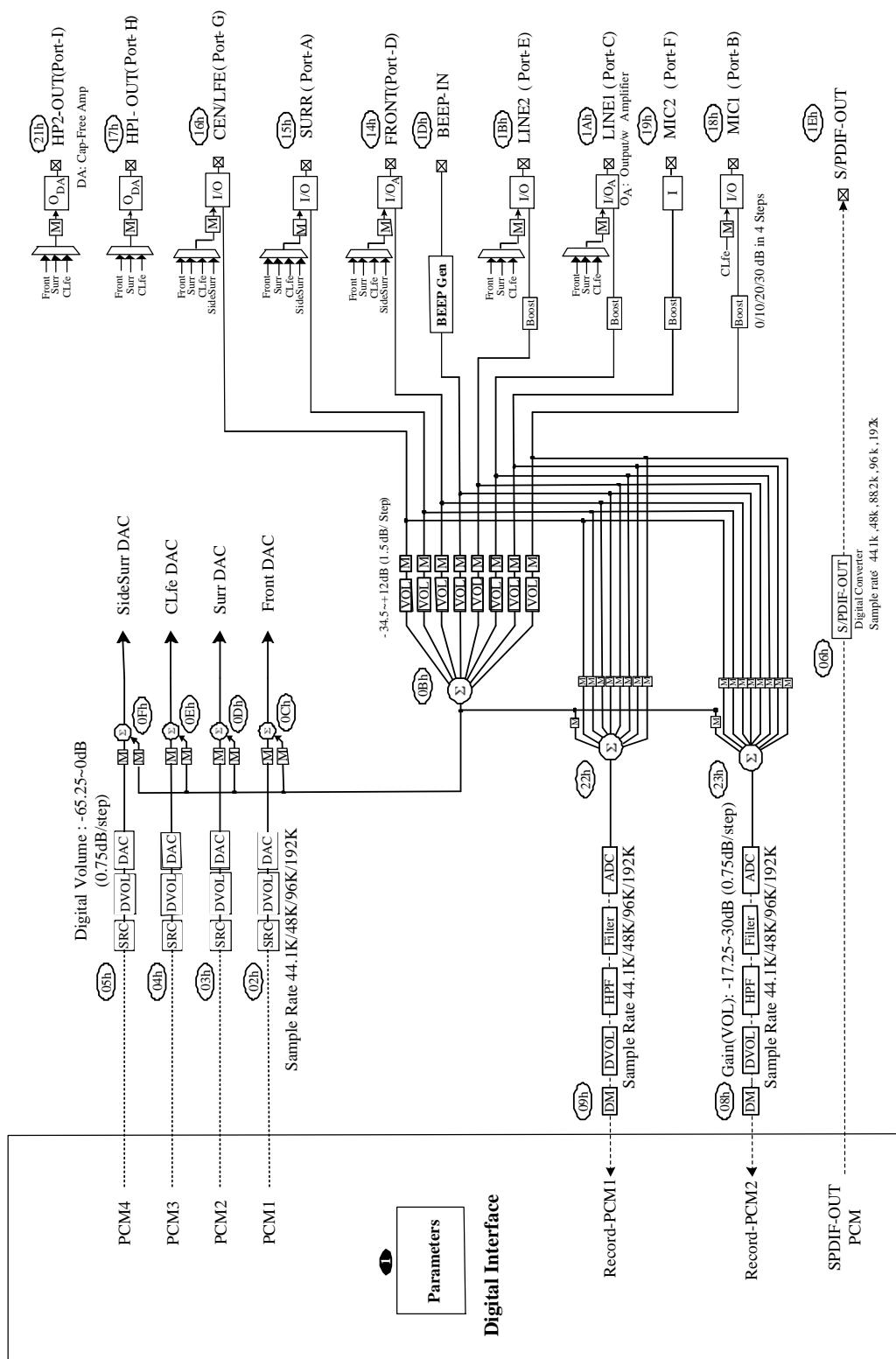

Figure 2. Block Diagram

3.1. Analog Input/Output Unit

Pin Complex widgets NID=14h, 15h, 16h, 18, 1A and 1Bh are re-tasking IOs. Only 14h and 1Ah support a traditional headphone amplifier.

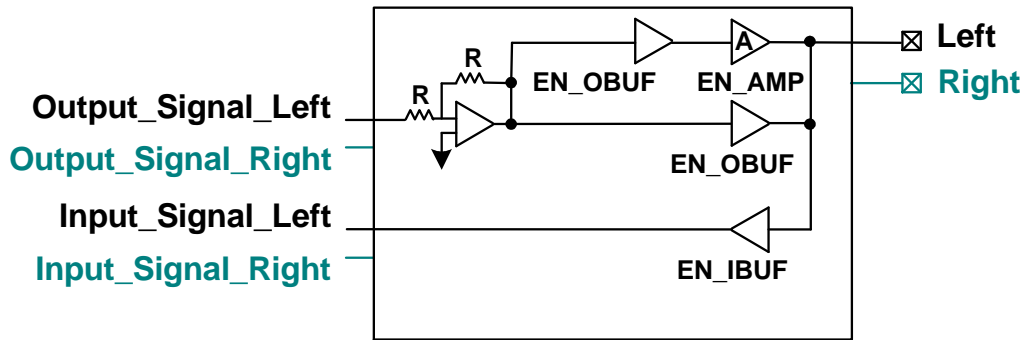

Figure 3. Analog Input/Output Unit

4. Pin Assignments

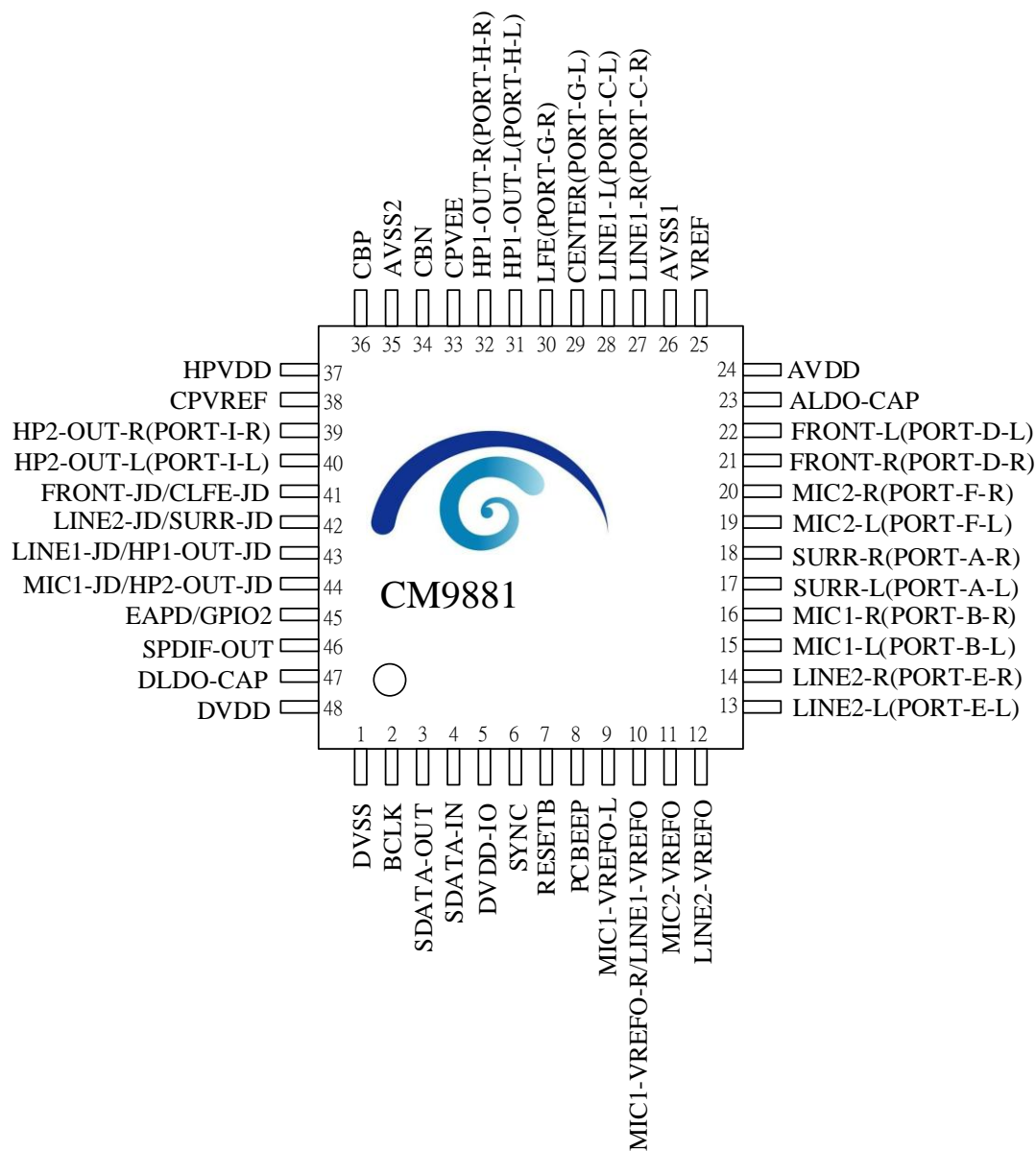

Figure 4. Pin Assignments

5. Pin Descriptions

Table 1. Pin Descriptions

Name	Type	Pin	Description	Characteristic Definition
DVSS	G	1	Digital Ground	Digital Ground
BITCLK	I	2	24MHz Clock	Digital Input: Schmitt Trigger. $V_{IL} = 0.4 \times DVDD\text{-IO}$, $V_{IH} = 0.6 \times DVDD\text{-IO}$
SDATA-OUT	I	3	Serial TDM Data Input	Digital Input: Schmitt Trigger. $V_{IL} = 0.4 \times DVDD\text{-IO}$, $V_{IH} = 0.6 \times DVDD\text{-IO}$
SDATA-IN	IO	4	Serial TDM Data Output	Digital Input: Schmitt Trigger. $V_{IL} = 0.4 \times DVDD\text{-IO}$, $V_{IH} = 0.6 \times DVDD\text{-IO}$ Digital Output: $V_{OL} < 0.1 \times DVDD\text{-IO}$, $V_{OH} > 0.9 \times DVDD\text{-IO}$
DVDD-IO	P	5	Digital Power for HD Link	Scalable Digital VDD (1.5V~3.3V)
SYNC	I	6	48KHz Frame SYNC Signal	Digital Input: Schmitt Trigger. $V_{IL} = 0.4 \times DVDD\text{-IO}$, $V_{IH} = 0.6 \times DVDD\text{-IO}$
RESETB	I	7	H/W Reset Input	Digital Input: Schmitt trigger, $V_{IL} = 0.4 \times DVDD\text{-IO}$, $V_{IH} = 0.6 \times DVDD\text{-IO}$
BEEP	I	8	External PC Beep Input	Analog Input: 1.6Vrms of full-scale input
MIC1-VREFO-L	O	9	Bias Voltage for MIC1 (Port-B)	Analog Output: 2.5V/3.2V/4.0V reference voltage
MIC1-VREFO-R / LINE1-VREFO	O	10	Secondary Bias Voltage for MIC1 (Port-B) / Bias Voltage for LINE1 (Port-C)	Analog Output: 2.5V/3.2V/4.0V reference voltage
MIC2-VREFO	O	11	Bias Voltage for MIC2 (Port-F)	Analog Output: 2.5V/3.2V/4.0V reference voltage
LINE2-VREFO	O	12	Bias Voltage for LINE2 (Port-E)	Analog Output: 2.5V/3.2V/4.0V reference voltage
LINE2-L	IO	13	Analog Input and Output with Multiple Function (Left)	Analog I/O (PORT-E-L), default 2 nd line input. Recommended to be microphone input at rear panel
LINE2-R	IO	14	Analog Input and Output with Multiple Function (Right)	Analog I/O (PORT-E-R), default 2 nd line input. Recommended to be microphone input at rear panel
MIC1-L	IO	15	Analog Input and Output with Multiple Function (Left)	Analog I/O (PORT-B-L), default 1 st mic input. Recommended to be re-tasking port at front panel
MIC1-R	IO	16	Analog Input and Output with Multiple Function (Right)	Analog I/O (PORT-B-R), default 1 st mic input. Recommended to be re-tasking port at front panel
SURR-L	IO	17	Analog Input and Output (Left)	Analog I/O (PORT-A-L), default surround channel
SURR-R	IO	18	Analog Input and Output (Right)	Analog I/O (PORT-A-R), default surround channel
MIC2-L	I	19	Analog Input (Left)	Analog I (PORT-F-L), default 2 nd mic input. Recommended to be re-tasking port at front panel with port-H-L

Name	Type	Pin	Description	Characteristic Definition
MIC2-R	I	20	Analog Input (Right)	Analog I (PORT-F-R), default 2 nd mic input. Recommended to be re-tasking port at front panel with port-H-R
FRONT-R	IO	21	Analog Input and Output (Right)	Analog I/O (PORT-D-R), default front channel output
FRONT-L	IO	22	Analog Input and Output (Left)	Analog I/O (PORT-D-L), default front channel output
ALDO-CAP	-	23	Built-In LDO Output for DAC/ADC and Mixer & Amp	Needs 10 μ F capacitor to analog ground, and short to Pin38
AVDD	P	24	Built-In LDO Input	VDD (5V)
VREF	-	25	0.5 \times ALDO-CAP Reference Voltage	10 μ F capacitor to analog ground
AVSS1	G	26	Analog Ground for Mixer & Amp	Analog GND
LINE1-R	IO	27	Analog Input and Output with Multiple Function (Right)	Analog I/O (PORT-C-R), default 1 st line input. Recommended to be line level input at rear panel
LINE1-L	IO	28	Analog Input and Output with Multiple Function (Left)	Analog I/O (PORT-C-L), default 1 st line input. Recommended to be line level input at rear panel
CENTER	IO	29	Analog Input and Output (Left)	Analog I/O (PORT-G-L), default center channel
LFE	IO	30	Analog Input and Output (Right)	Analog I/O (PORT-G-R), default LFE channel
HP1-OUT-L	O	31	Headphone Out Left Channel	Analog output (Port-H) Recommended to be re-tasking port at front panel with port-F-L
HP1-OUT-R	O	32	Headphone Out Right Channel	Analog output (Port-H) Recommended to be re-tasking port at front panel with port-F-R
CPVEE	-	33	Reference Voltage Output	2.2 μ F capacitor to digital ground
CBN	-	34	Reference Capacitor	2.2 μ F capacitor to CBP
AVSS2	G	35	Analog GND	Analog ground for capless amplifier
CBP	-	36	Reference Capacitor	2.2 μ F capacitor to CBN
HPVDD	P	37	Capless Amplifier VDD (3.3V)	Power supply for cap-saving HP AMP & its charge pump
CPVREF	-	38	Capless reference ground	Reference for capless amplifier
HP2-OUT-R	O	39	Headphone Out Right Channel	Analog output (Port-I)
HP2-OUT-L	O	40	Headphone Out Left Channel	Analog output (Port-I)
JD1	I	41	Jack Detect for FRONT and CLFE port	Internal pull high/low/float programmable PIN. 3 thresholds to detect 4 states 2.2V/1.65V/1.32V (Option for 1 pin detects 1 port)
JD2	I	42	Jack Detect for LINE2 and SURR port	Internal pull high/low/float programmable PIN 3 thresholds to detect 4 states 2.2V/1.65V/1.32V (Option for 1 pin detects 1 port)
JD3	I	43	Jack Detect for LINE1 and HP1-OUT port	Internal pull high/low/float programmable PIN 3 thresholds to detect 4 states 2.2V/1.65V/1.32V (Option for 1 pin detects 1 port)

Name	Type	Pin	Description	Characteristic Definition
JD4	I	44	Jack Detect for MIC1 and HP2-OUT port	Internal pull high/low/float programmable PIN 3 thresholds to detect 4 states 2.2V/1.65V/1.32V (Option for 1 pin detects 1 port)
EAPD/ GPIO2	IO	45	External Amplifier Power Down/ General Purpose Input/Output	Digital Input: Schmitt trigger $V_{TH} = 1.4$ (Floating) Digital Output: $V_{OL} < 0.1 \times DVDD$, $V_{OH} > 0.9 \times DVDD$
SPDIF-OUT	O	46	SPDIF Out	Digital Output: $V_{OL} < 0.1 \times DVDD$, $V_{OH} > 0.9 \times DVDD$ 10mA@75Ω Output driving
DLDO-CAP	-	47	Reference for Integrated Regulator	10μF capacitor to digital ground
DVDD	P	48	Digital Core Power	Digital VDD (3.3V)
				Total: 48 Pins

6. High Definition Audio Link Protocol

6.1. Link Signals

The High Definition Audio (HDA) link is the digital serial interface that connects the HDA codecs to the HDA Controller. The HDA link protocol is controller synchronous, based on a 24.0MHz BIT-CLK sent by the HDA controller. The input and output streams, including command and PCM data, are isochronous with a 48kHz frame rate. Figure 5 shows the basic concept of the HDA link protocol.

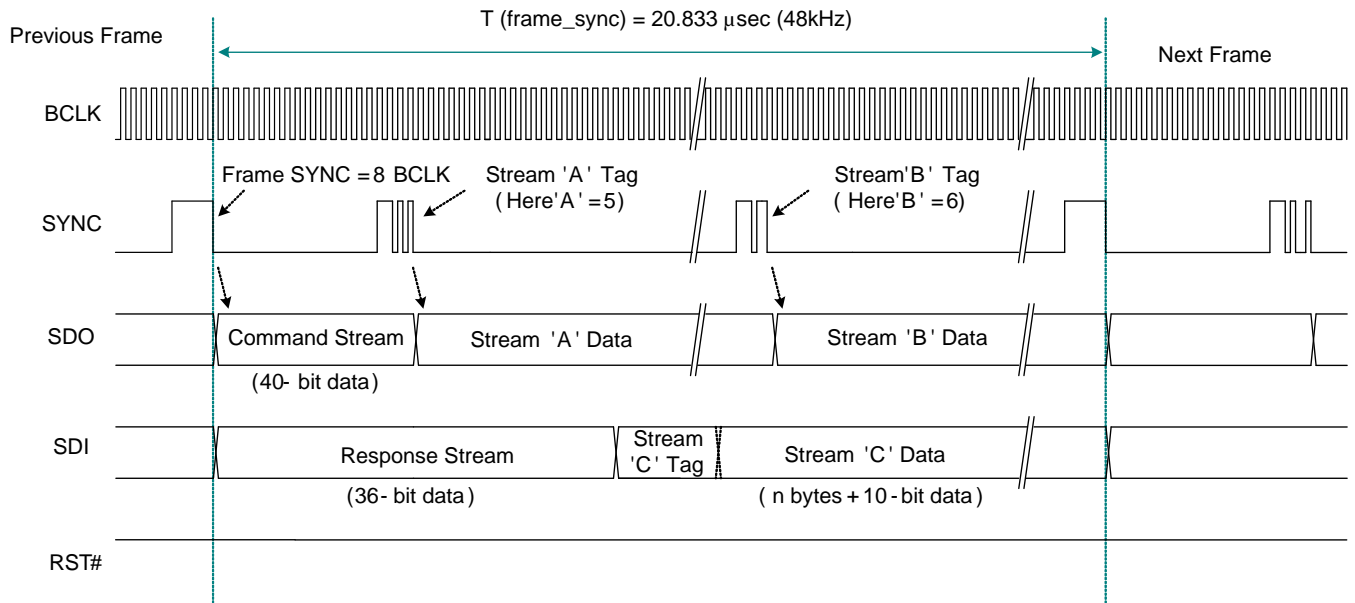

Figure 5. HDA Link Protocol

6.1.1. Link Signal Definitions

Table 2. Link Signal Definitions

Item	Description
BCLK	24.0MHz bit clock sourced from the HDA controller and connecting to all codecs
SYNC	48kHz signal used to synchronize input and output streams on the link. It is sourced from the HDA controller and connects to all codecs
SDO	Serial data output signal driven by the HDA controller to all codecs. Commands and data streams are carried on SDO. The data rate is double pumped; the controller drives data onto the SDO, the codec samples data present on SDO with respect to each edge of BCLK. The HDA controller must support at least one SDO. To extend outbound bandwidth, multiple SDOs may be supported
SDI	Serial data input signal driven by the codec. This is point-to-point serial data from the codec to the HDA controller. The controller must support at least one SDI, and up to a maximum of 15 SDI's can be supported. SDI is driven by the codec at each rising edge of BCLK, and sampled by the controller at each rising edge of BCLK. SDI can be driven by the controller to initialize the codec's ID
RST#	Active low reset signal. Asserted to reset the codec to default power on state. RST# is sourced from the HDA controller and connects to all codecs

Table 3. HDA Signal Definitions

Signal Name	Source	Type for Controller	Description
BCLK	Controller	Output	Global 24.0MHz Bit Clock
SYNC	Controller	Output	Global 48kHz Frame Sync and Outbound Tag Signal
SDO	Controller	Output	Serial Data Output from the Controller
SDI	Codec/Controller	Input/Output	Serial Data Input from Codec. Weakly pulled down by the controller
RST#	Controller	Output	Global Active Low Reset Signal

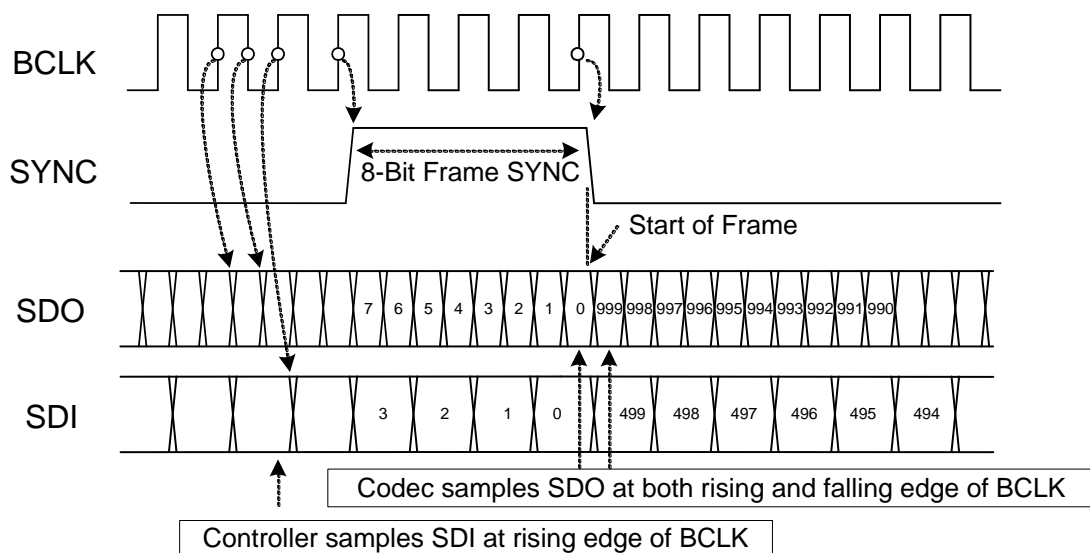

Figure 6. Bit Timing

6.1.2. Signaling Topology

The HDA controller supports two SDOs for the outbound stream, up to 15 SDIs for the inbound stream. RST#, BCLK, SYNC, SDO0, and SDO1 are driven by controller to codecs. Each codec drives its own point-to-point SDI signal(s) to the controller.

Figure 7 shows the possible connections between the HDA controller and codecs:

- Codec 0 is a basic connection. There is one single SDO and one single SDI for normal transmission
- Codec 1 has two SDOs for doubled outbound rate, a single SDI for normal inbound rate
- Codec 3 supports a single SDO for normal outbound rate, and two SDIs for doubled inbound rate
- Codec N has two SDOs and multiple SDIs

The multiple SDOs and multiple SDIs are used to expand the transmission rate between controller and codecs. Section 6.2 Frame Composition, page 13 describes the detailed outbound and inbound stream compositions for single and multiple SDOs/SDIs.

The connections shown in Figure 7 can be implemented concurrently in an HDA system. The CM9881 is designed to receive a single SDO stream.

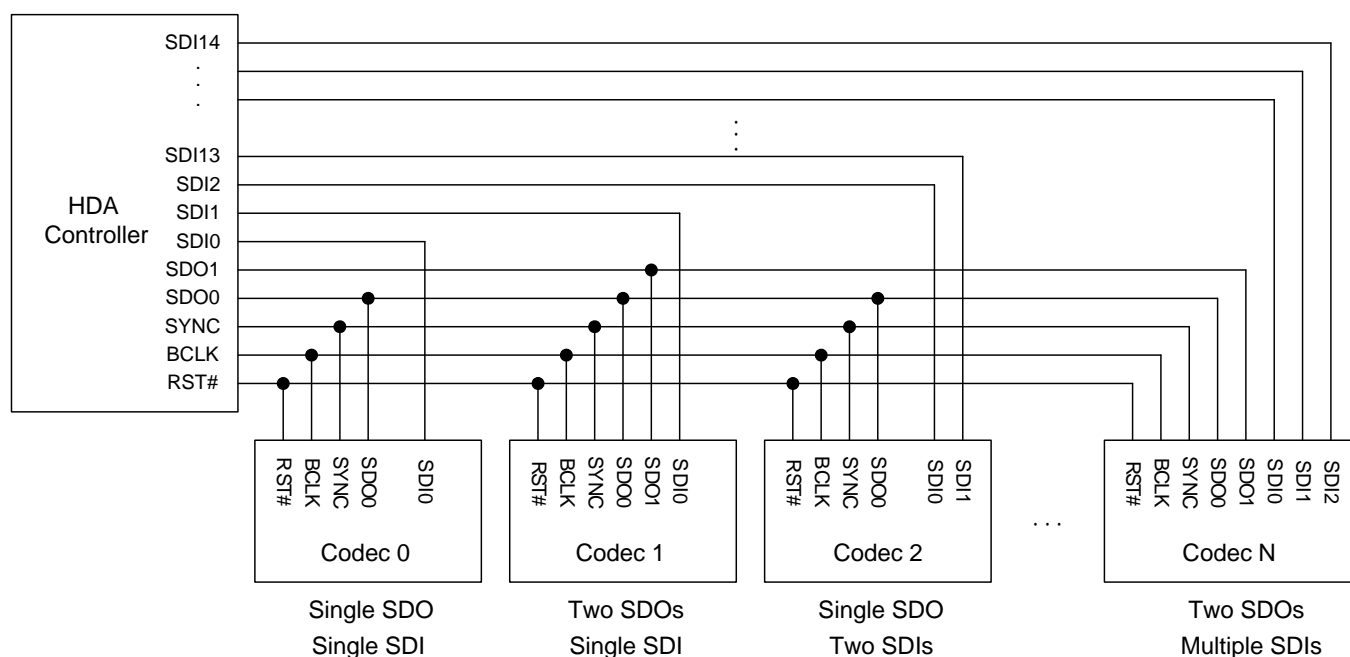

Figure 7. Signaling Topology

6.2. Frame Composition

6.2.1. Outbound Frame – Single SDO

An outbound frame is composed of one 32-bit command stream and multiple data streams. There are one or multiple sample blocks in a data stream. Only one sample block exists in a stream if the HDA controller delivers a 48kHz rate of samples to the codec. Multiple sample blocks in a stream means the sample rate is a multiple of 48kHz. This means there should be two blocks in the same stream to carry 96kHz samples (Figure 8).

For outbound frames, the stream tag is not in SDO, but in the SYNC signal. A new data stream is started at the end of the stream tag. The stream tag includes a 4-bit preamble and 4-bit stream ID (Figure 9).

To keep the cadence of converters bound to the same stream, samples for these converters must be placed in the same block.

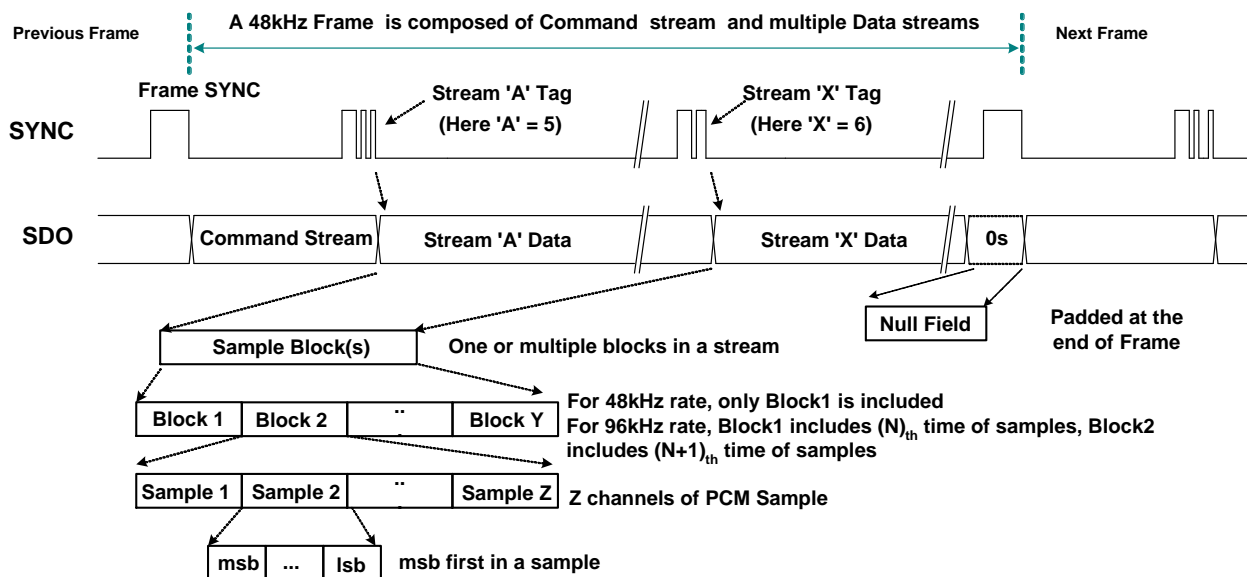

Figure 8. SDO Outbound Frame

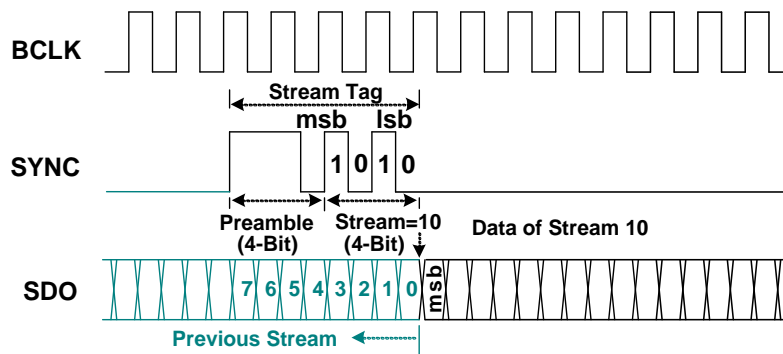

Figure 9. SDO Stream Tag is Indicated in SYNC

6.2.2. Outbound Frame – Multiple SDOs

The HDA controller allows two SDO signals to be used to stripe outbound data, completing transmission in less time to get more bandwidth. If software determines the target codec supports multiple SDO capability, it enables the ‘Stripe Control’ bit in the controller’s Output Stream Control Register to initiate a specific stream (Stream ‘A’ in Figure 10) to be transmitted on multiple SDOs. In this case, the MSB of the data stream is always carried on SDO0, the second bit on SDO1 and so forth.

SDO1 is for transmitting a striped stream. The codec does not support multiple SDOs connected to SDO0.

To guarantee all codecs can determine their corresponding stream, the command stream is not striped. It is always transmitted on SDO0, and copied on SDO1.

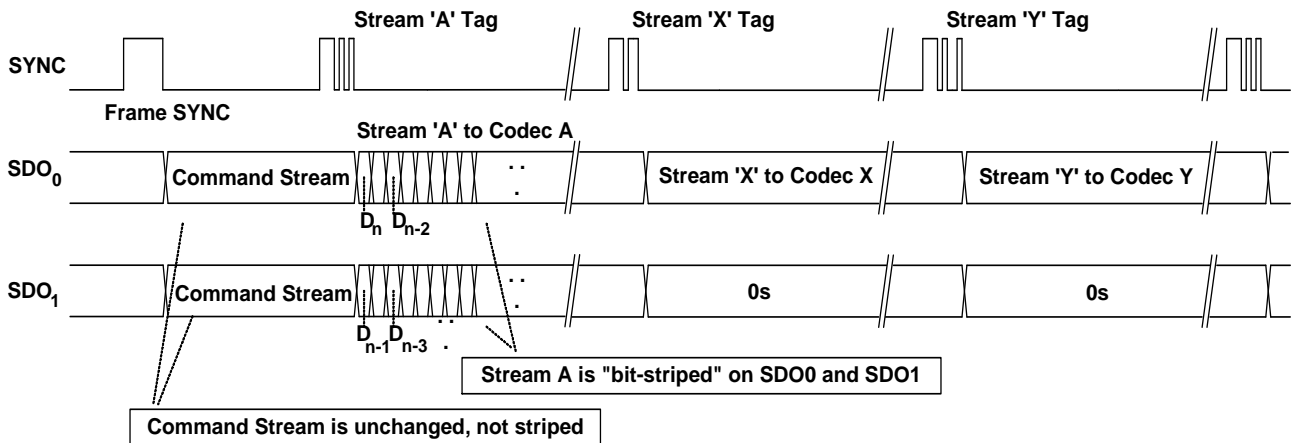

Figure 10. Striped Stream on Multiple SDOs

6.2.3. Inbound Frame – Single SDI

An Inbound Frame – A single SDI is composed of one 36-bit response stream and multiple data streams. Except for the initialization sequence (turnaround and address frame), the SDI is driven by the codec at each rising edge of BCLK. The controller also samples data at the rising edge of BCLK.

The SDI stream tag is not carried by SYNC, but included in the SDI. A complete SDI data stream includes one 4-bit stream tag, one 6-bit data length, and n-bit sample blocks. Zeros will be padded if the total length of the contiguous sample blocks within a given stream is not of integral byte length (Figure 12).

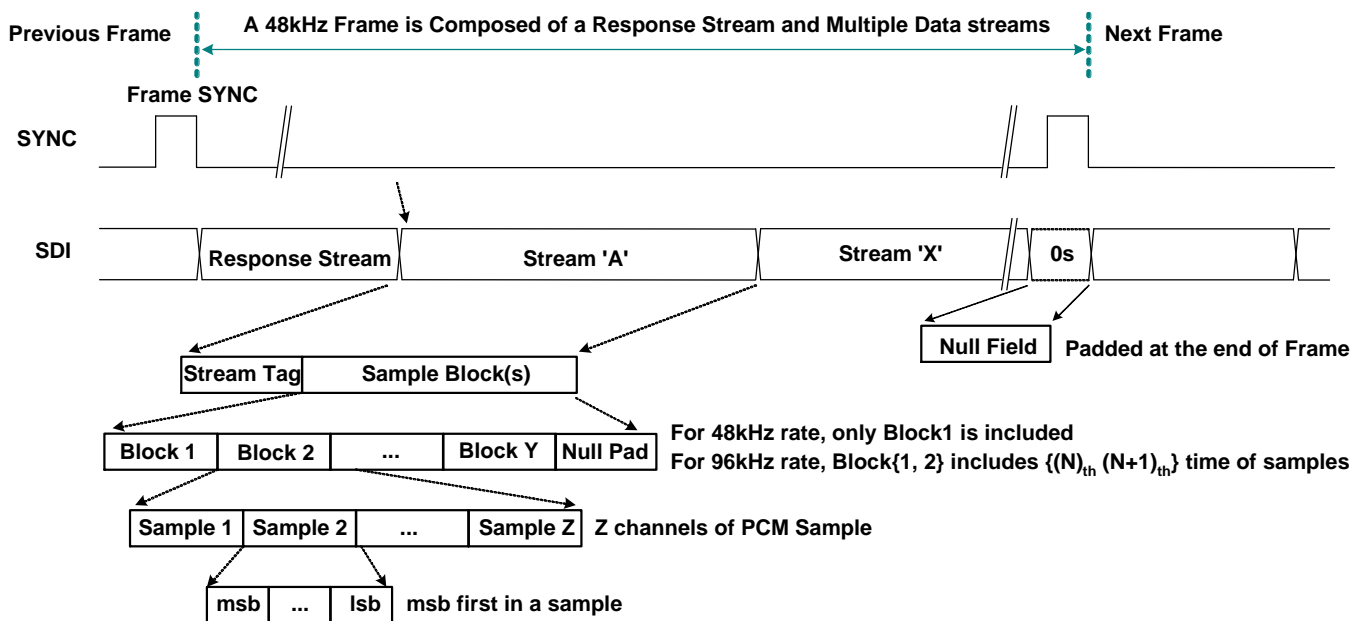

Figure 11. SDI Inbound Stream

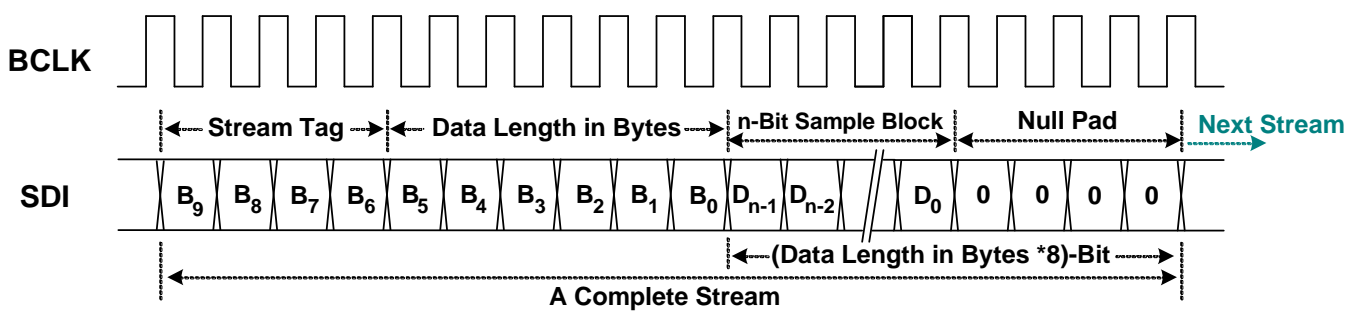

Figure 12. SDI Stream Tag and Data

6.2.4. Inbound Frame – Multiple SDIs

A codec can deliver data to the controller on multiple SDIs to achieve higher bandwidth. If an inbound stream exceeds the data transfer limits of a single SDI, the codec can divide the data into separate SDI signals, each of which operate independently, with different stream numbers at the same frame time. This is similar to having multiple codecs connected to the controller. The controller samples the divided stream into separate memory with multiple DMA descriptors, then software re-combines the divided data into a meaningful stream.

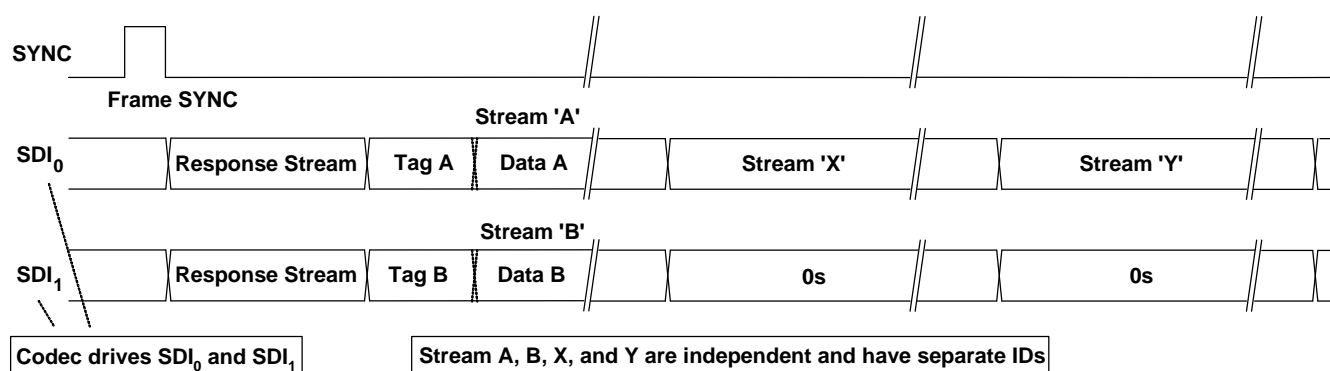

Figure 13. Codec Transmits Data Over Multiple SDIs

6.2.5. Variable Sample Rates

The HDA link is designed for sample rates of 48kHz. Variable rates of sample are delivered in multiple or sub-multiple rates of 48kHz. Two sample blocks per frame result in a 96kHz delivery rate, one sample block over two frames results in a 24kHz delivery rate. The HDA specification states that the sample rate of the outbound stream be synchronized by the controller, not by the codec. Each stream has its own sample rate, independent of any other stream.

The HDA controller supports 48kHz and 44.1kHz base rates. Table 4, page 17, shows the recommended sample rates based on multiples or sub-multiples of one of the two base rates.

Rates in sub-multiples (1/n) of 48kHz are interleaving n frames containing no sample blocks. Rates in multiples (n) of 48kHz contain n sample blocks in a frame. Table 5, page 17, shows the delivery cadence of variable rates based on 48kHz.

The HDA link is defined to operate at a fixed 48kHz frame rate. To deliver samples in (sub) multiple rates of 44.1kHz, an appropriate ratio between 44.1kHz and 48kHz must be maintained to avoid frequency drift. The appropriate ratio between 44.1kHz and 48kHz is 147/160. Meaning 147 sample blocks are transmitted every 160 frames.

The cadence ‘12-11-11-12-11-11-12-11-11-12-11-11-11- (repeat)’ interleaves 13 frames containing no sample blocks in every 160 frames. It provides a low long-term frequency drift for 44.1kHz of delivery rate. Rates in sub-multiples (1/n) of 44.1kHz also follow this cadence AND interleave n empty frames. Rates in multiples (n) of 44.1kHz applying this cadence contain n sample blocks in the non-empty frame AND interleave an empty frame between non-empty frames (Table 6, page 18).

Table 4. Defined Sample Rate and Transmission Rate

(Sub) Multiple	48kHz Base	44.1kHz Base
1/6	8kHz (1 Sample Block Every 6 Frames)	-
1/4	12kHz (1 Sample Block Every 4 Frames)	11.025kHz (1 Sample Block Every 4 Frames)
1/3	16kHz (1 Sample Block Every 3 Frames)	-
1/2	-	22.05kHz (1 Sample Block Every 2 Frames)
2/3	32kHz (2 Sample Blocks Every 3 Frames)	-
1	48kHz (1 Sample Block per Frame)	44.1kHz (1 Sample Block per Frame)
2	96kHz (2 Sample Blocks per Frame)	88.2kHz (2 Sample Blocks per Frame)
4	192kHz (4 Sample Blocks per Frame)	176.4kHz (4 Sample Blocks per Frame)

Table 5. 48kHz Variable Rate of Delivery Timing

Rate	Delivery Cadence	Description
8kHz	YNNNNN (Repeat)	One Sample Block is Transmitted in Every 6 Frames
12kHz	YNNN (Repeat)	One Sample Block is Transmitted in Every 4 Frames
16kHz	YNN (Repeat)	One Sample Block is Transmitted in Every 3 Frames
32kHz	Y ² NN (Repeat)	Two Sample Blocks are Transmitted in Every 3 Frames
48kHz	Y (Repeat)	One Sample Block is Transmitted in Every Frame
96kHz	Y ² (Repeat)	Two Sample Blocks are Transmitted in Each Frame
192kHz	Y ⁴ (Repeat)	Four Sample Blocks Are Transmitted In Each Frame

N: No sample block in a frame.

Y: One sample block in a frame.

Yx: X sample blocks in a frame.

6.3. Reset and Initialization

There are two types of reset within an HDA link:

- Link Reset. Generated by assertion of the RST# signal, all codecs return to their power on state
- Codec Reset. Generated by software directing a command to reset a specific codec back to its default state

An initialization sequence is requested after any of the following three events:

- Link Reset
- Codec Reset
- Codec changes its power state (for example, hot docking a codec to an HDA system)

6.3.1. Link Reset

A link reset may be caused by 3 events:

1. The HDA controller asserts RST# for any reason (power up, or PCI reset)
2. Software initiates a link reset via the 'CRST' bit in the Global Control Register (GCR) of the HDA controller
3. Software initiates power management sequences. Figure 14, shows the 'Link Reset' timing including the 'Enter' sequence (①~⑤) and 'Exit' sequence (⑥~⑨)

Enter 'Link Reset':

- ① Software writes a 0 to the 'CRST' bit in the Global Control Register of the HDA controller to initiate a link reset
- ② When the controller completes the current frame, it does not signal the normal 8-bit frame SYNC at the end of the frame
- ③ The controller drives SYNC and all SDOs to low. Codecs also drive SDIs to low
- ④ The controller asserts the RST# signal to low, and enters the 'Link Reset' state
- ⑤ All link signals driven by controller and codecs should be tri-state by internal pull low resistors

Exit from ‘Link Reset’:

- ⑥ If BCLK is re-started for any reason (codec wake-up event, power management, etc.)
- ⑦ Software is responsible for de-asserting RST# after a minimum of 100µs BCLK running time (the 100µsec provides time for the codec PLL to stabilize)
- ⑧ Minimum of 4 BCLK after RST# is de-asserted, the controller starts to signal normal frame SYNC
- ⑨ When the codec drives its SDI to request an initialization sequence (when the SDI is driven high at the last bit of frame SYNC, it means the codec requests an initialization sequence)

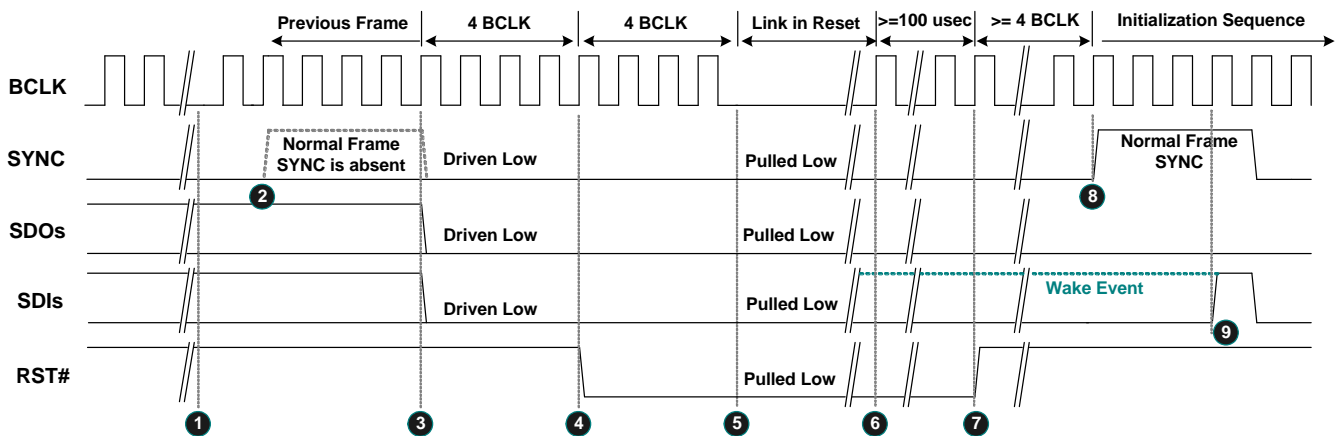

Figure 14. Link Reset Timing

6.3.2. Codec Reset

A ‘Codec Reset’ is initiated via the codec RESET command verb. It results in the target codec being reset to the default state. After the target codec completes its reset operation, an initialization sequence is requested.

6.3.3. Codec Initialization Sequence

- ❶ The codec drives SDI high at the last bit of SYNC to request a Codec Address (CAD) from the controller
- ❷ The codec will stop driving the SDI during this turnaround period
- ❸❹❺❻ The controller drives SDI to assign a CAD to the codec
- ❼ The controller releases the SDI after the CAD has been assigned
- ❽ Normal operation state

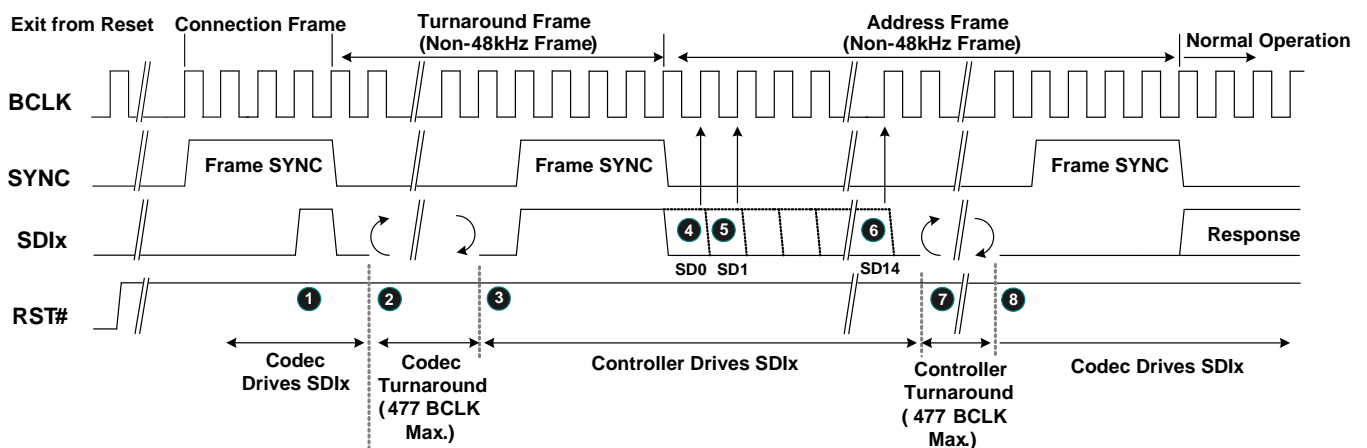

Figure 15. Codec Initialization Sequence

6.4. Verb and Response Format

6.4.1. Command Verb Format

There are two types of verbs: one with 4-bit identifiers (4-bit verbs) and 16-bits of data, the other with 12-bit identifiers (12-bit verbs) and 8-bits of data. Table 7 shows the 4-bit verb structure of a command stream sent from the controller to operate the codec. Table 8 is the 12-bit verb structure that gets and controls parameters in the codec.

Table 7. 40-Bit Commands in 4-Bit Verb Format

Bit [39:32]	Bit [31:28]	Bit [27:20]	Bit [19:16]	Bit [15:0]
Reserved	Codec Address	Node ID	Verb ID	Payload

Table 8. 40-Bit Commands in 12-Bit Verb Format

Bit [39:32]	Bit [31:28]	Bit [27:20]	Bit [19:8]	Bit [7:0]
Reserved	Codec Address	Node ID	Verb ID	Payload

Table 9. Verbs Supported by the CM9881 (Y=Supported)

Supported Verb	Get Verb	Set Verb	Root Node	Audio Function Group	Modem Function Group ^{*1}	HDMI Function Group ^{*1}	Vendor Defined Group ^{*1}	Audio Out Converter	Audio In Converter	Pin Widget	Sum Widget	Selector Widget	Power Widget ^{*1}	Volume Knob	Beep Generator	Vendor Defined Widget
Get Parameter	F00	-	Y	Y	-	-	-	Y	Y	Y	Y	Y	-	Y	Y	Y
Connection Select	F01	701	-	-	-	-	-	-	Y	Y	-	Y	-	-	-	-
Get Connection List Entry	F02	-	-	-	-	-	-	-	Y	Y	Y	Y	-	-	-	-
Processing State	F03	703	-	-	-	-	-	-	-	-	-	-	-	-	-	-
Coefficient Index	D-	5-	-	-	-	-	-	-	-	-	-	-	-	-	-	Y
Processing Coefficient	C-	4-	-	-	-	-	-	-	-	-	-	-	-	-	-	Y
Amplifier Gain/Mute	B-	3-	-	-	-	-	-	-	Y	Y	Y	-	-	-	-	-
Stream Format	A-	2-	-	-	-	-	-	Y	Y	-	-	-	-	-	-	-
Digital Converter 1	F0D	70D	-	-	-	-	-	Y	Y	-	-	-	-	-	-	-
Digital Converter 2	F0D	70E	-	-	-	-	-	Y	Y	-	-	-	-	-	-	-
Digital Converter 3	F3E	73E	-	-	-	-	-	Y	Y	-	-	-	-	-	-	-
Digital Converter 4	F3F	73F	-	-	-	-	-	Y	Y	-	-	-	-	-	-	-
Power State	F05	705	-	Y	-	-	-	-	-	-	-	-	-	-	-	-
Channel/Stream ID	F06	706	-	-	-	-	-	Y	Y	-	-	-	-	-	-	-
SDI Select	F04	704	-	-	-	-	-	-	-	-	-	-	-	-	-	-
Pin Widget Control	F07	707	-	-	-	-	-	-	-	Y	-	-	-	-	-	-
Unsolicited Enable	F08	708	-	-	-	-	-	-	-	Y	-	-	-	Y	-	-
Pin Sense	F09	709	-	-	-	-	-	-	-	Y	-	-	-	-	-	-
EAPD/BTL Enable	F0C	70C	-	-	-	-	-	-	-	Y	-	-	-	-	-	-
All GPIO Control	F15~ F19	715~ 719	-	Y	-	-	-	-	-	-	-	-	-	-	-	-
Beep Generator Control	F0A	70A	-	-	-	-	-	-	-	-	-	-	-	-	Y	-
Volume Knob Control	F0F	70F	-	-	-	-	-	-	-	-	-	-	-	Y	-	-
Subsystem ID, Byte 0	F20	720	-	Y	-	-	-	-	-	-	-	-	-	-	-	-
Subsystem ID, Byte 1	F20	721	-	Y	-	-	-	-	-	-	-	-	-	-	-	-
Subsystem ID, Byte 2	F20	722	-	Y	-	-	-	-	-	-	-	-	-	-	-	-
Subsystem ID, Byte 3	F20	723	-	Y	-	-	-	-	-	-	-	-	-	-	-	-
Config Default, Byte 0	F1C	71C	-	-	-	-	-	-	-	Y	-	-	-	-	-	-
Config Default, Byte 1	F1C	71D	-	-	-	-	-	-	-	Y	-	-	-	-	-	-
Config Default, Byte 2	F1C	71E	-	-	-	-	-	-	-	Y	-	-	-	-	-	-
Config Default, Byte 3	F1C	71F	-	-	-	-	-	-	-	Y	-	-	-	-	-	-
RESET	-	7FF	-	Y	-	-	-	-	-	-	-	-	-	-	-	-

*1: The CM9881 does not support Modem Function, HDMI Function, Vendor Defined Groups, and Power Widgets.

Table 10. Parameters in the CM9881 (Y=Supported)

Supported Parameter	Parameter ID	Root Node	Audio Function Group	Modem Function Group ^{*1}	HDMI Function Group ^{*1}	Vendor Defined Group ^{*1}	Audio Out Converter	Audio In Converter	Pin Widget	Sum Widget	Selector Widget	Power Widget ^{*1}	Volume Knob	Beep Generator	Vendor Defined Widget
Vendor ID	00	Y	-	-	-	-	-	-	-	-	-	-	-	-	-
Revision ID	02	Y	-	-	-	-	-	-	-	-	-	-	-	-	-
Subordinate Node Count	04	Y	Y	-	-	-	-	-	-	-	-	-	-	-	-
Function Group Type	05	-	Y	-	-	-	-	-	-	-	-	-	-	-	-
Audio Function Group Capabilities	08	-	Y	-	-	-	-	-	-	-	-	-	-	-	-
Audio Widget Capabilities	09	-	-	-	-	-	Y	Y	Y	Y	Y	-	Y	Y	Y
Sample Size, Rate	0A	-	Y	-	-	-	Y	Y	-	-	-	-	-	-	-
Stream Formats	0B	-	Y	-	-	-	Y	Y	-	-	-	-	-	-	-
Pin Capabilities	0C	-	-	-	-	-	-	-	Y	-	-	-	-	-	-
Input Amp Capabilities	0D	-	-	-	-	-	-	Y	-	Y	Y	-	-	-	-
Output Amp Capabilities	12	-	-	-	-	-	-	-	Y	Y	-	-	-	-	-
Connection List Length	0E	-	-	-	-	-	-	Y	Y	Y	Y	-	-	-	-
Supported Power States	0F	-	Y	-	-	-	Y	Y	Y	Y	Y	-	-	-	Y
Processing Capabilities	10	-	-	-	-	-	-	-	-	-	-	-	-	-	Y
GPIO Count	11	-	-	-	-	-	-	-	-	-	-	-	-	-	-
Volume Knob Capabilities	13	-	-	-	-	-	-	-	-	-	-	-	Y	-	-

^{*1}: The CM9881 does not support Modem Function, HDMI Function, Vendor Defined Groups, and Power Widgets.

6.4.2. Response Format

There are two types of response from the codec to the controller. Solicited Responses are returned by the codec in response to a current command verb. The codec will send Solicited Response data in the next frame, without regard to the Set (Write) or Get (Read) command. The 32-bit Response is interpreted by software, opaque to the controller.

Unsolicited Responses are sent by the codec independently of software requests. Jack Detection or GPI status information can be actively delivered to the controller and interpreted by software. The ‘Tag’ in Bit[31:28] is used to identify unsolicited events. This tag is undefined in the HDA specifications.

Table 11. Solicited Response Format

Bit [35]	Bit [34]	Bit [33:32]	Bit [31:0]
Valid	Unsol=0	Reserved	Response

Table 12. Unsolicited Response Format

Bit [35]	Bit [34]	Bit [33:32]	Bit [31:28]	Bit [27:0]
Valid	Unsol=1	Reserved	Tag	Response

Note: The response stream in the link protocol is 36-bits wide. The response is placed in the lower 32-bit field. Bit 35 is a ‘Valid’ bit to indicate the response is ‘Ready’. Bit 34 is set to indicate that an unsolicited response was sent.

6.5. Power Management

All power management state changes in widgets are driven by software. Table 13 shows the System Power State Definitions. To simplify power management in the CM9881, only the Audio Function (NID=01h) supports power control. Output converters (DACs) and input converters (ADCs) have no individual power control. Software can configure whole codec power states through the audio function (NID=01h). Software may have various power states depending on system configuration.

Table 14 indicates those nodes that support power management.

6.5.1. System Power State Definitions

Table 13. System Power State Definitions

Power States	Definitions
D0	All Power On. Individual DACs and ADCs can be powered up or down as required.
D1	All Converters (DACs and ADCs) are Powered Down. State maintained, analog reference stays up.
D2	Power is Still Supplied. All amplifiers and converters (DACs and ADCs) are powered down. Codec stops PLL. State maintained. Jack-detection and GPI are powered down.
D3 (Hot)	Power is Still Supplied. All amplifiers and converters (DACs and ADCs) are powered down. Codec stops PLL. State maintained. Jack-detection/GPI work.
D3 (Cold)	Power is Still Supplied. All amplifiers and converters (DACs and ADCs) are powered down. Codec stops PLL. State maintained. Jack-detection/GPI work when internal OSC powers up.

6.5.2. Power Controls in NID 01h

Table 14. Power Controls in NID 01h

Item	Description	D0	D1	D2	D3	Link Reset
Audio Function (NID=01h)	HD LINK State	Normal	Normal	Normal	Normal	PD
	Front DAC (NID-02h)	Normal	PD	PD	PD	PD
	Surr DAC (NID-03h)	Normal	PD	PD	PD	PD
	Cen/Lfe DAC (NID-04h)	Normal	PD	PD	PD	PD
	Side DAC (NID-05h)	Normal	PD	PD	PD	PD
	LINE ADC (NID-08h)	Normal	PD	PD	PD	PD
	MIX ADC (NID-09h)	Normal	PD	PD	PD	PD
	All Headphone Drivers	Normal	Normal	PD	PD	PD
	All Mixers	Normal	Normal	PD	PD	PD
	All Reference	Normal	Normal	Normal	Normal	Normal
	Jack Detection with Unsolicited Response	Normal	Normal	PD	Normal	Normal ²
	Jack Detection with Unsolicited Response	Normal	Normal	PD	Normal	Normal ²

6.5.3. Powered Down Conditions

Table 15. Powered Down Conditions

Condition	Description
LINK Response Powered Down	Internal Clock is Stopped. SDATA-IN and SPDIF-OUT are floated with internally pulled low 47K resistors. SPDIF-IN is also floated. Detection of 'Link Reset Entry' and 'Link Reset Exit' sequences is supported. All states are maintained if DVDD is supplied.
FRONT DAC Powered Down	Analog Block and Digital Filter are Powered Down.
SURR DAC Powered Down	Analog Block and Digital Filter are Powered Down.
CEN/LFE DAC Powered Down	Analog Block and Digital Filter are Powered Down.
SIDESURR DAC Powered Down	Analog Block and Digital Filter are Powered Down.
LINE ADC Powered Down	Analog Block and Digital Filter are Powered Down. Data on SDATA-IN is quiet.
MIX ADC Powered Down	Analog Block and Digital Filter are Powered Down. Data on SDATA-IN is quiet.
Headphone Driver Powered Down	All Headphone Drivers are Powered Down.
Mixers Powered Down	All Internal Mixer Widgets are Powered Down. The DC reference and VREFOUTx at individual pin complexes are still alive.
Reference Power Down	All Internal References, DC Reference, and VREFOUTx at Individual Pin Complexes are Off.

7. Supported Verbs and Parameters

This section describes the Verbs and Parameters supported by various widgets in the CM9881. If a verb is not supported by the addressed widget, it will respond with 32 bits of '0'.

7.1. Verb – Get Parameters (Verb ID=F00h)

The 'Get Parameters' verb is used to get system information and the function capabilities of the HDA codec. All the parameters are read-only. There are a total of 15 ID parameters defined for each widget. Some parameters are supported only in a specific widget. Refer to section 6.4.1 Command Verb Format, page 21, for detailed information about supported parameters.

Table 16. Verb – Get Parameters (Verb ID=F00h)

Get Parameter Command Format				Codec Response Format
Bit [31:28]	Bit [27:20]	Bit [19:8]	Payload Bit [7:0]	Response [31:0]
CAd=X	Node ID=00h	Verb ID=F00h	Parameter ID[7:0]	32-bit Response

Note: If the parameter ID is not supported, the returned response is 32 bits of '0'.

7.1.1. Parameter – Revision ID (Verb ID=F00h, Parameter ID=02h)

Table 17. Parameter – Revision ID (Verb ID=F00h, Parameter ID=02h)

Codec Response Format	
Bit	Description
31:24	Reserved. Read as 0's.
23:20	MajRev. The major version number (in decimal) of the HDA Spec to which the CM9881 is fully compliant. Response=0x1.
19:16	MinRev. The minor version number (in decimal) of the HDA Spec to which the CM9881 is fully compliant. Response=0x0.
15:8	Revision ID. The vendor's revision number. 00h is for the first silicon version (A version), 01h is for the second version (B version), etc.
7:0	Stepping ID. The vendor's stepping number within the given Revision ID.

Note: The Root Node (NID=00h in the CM9881) supports this parameter.

7.1.2. Parameter – Subordinate Node Count (Verb ID=F00h, Parameter ID=04h)

For the root node, the Subordinate Node Count provides information about audio function group nodes associated with the root node.

For function group nodes, it provides the total number of widgets associated with this function node.

Table 18. Parameter – Subordinate Node Count (Verb ID=F00h, Parameter ID=04h)

Codec Response Format

Bit	Description
31:24	Reserved. Read as 0's.
23:16	Starting Node Number. The starting node number in the sequential widgets.
15:8	Reserved. Read as 0's.
7:0	Total Number of Nodes. For a root node, the total number of function groups in the root node. For a function group, the total number of widget nodes in the function group.

	Description	Reserved	Starting Node	Reserved	Total Fun/Widgets
	Bits →	Bit [31:24]	Bit [23:16]	Bit [15:8]	Bit [7:0]
Root Node	NID=00h	-	01h	-	01h
Audio Function	NID=01h	-	02h	-	22h
Others	Not Supported (Returns 00000000h)				

7.1.3. Parameter – Function Group Type (Verb ID=F00h, Parameter ID=05h)

Table 19. Parameter – Function Group Type (Verb ID=F00h, Parameter ID=05h)

Codec Response Format

Bit	Description
31:9	Reserved. Read as 0's.
8	UnSol Capable. Read as 1. 0: Unsolicited response is not supported by this function group 1: Unsolicited response is supported by this function group
7:0	Function Group Type. Read as 01h. 00h: Reserved 01h: Audio Function 02h: Modem Function 03h~7Fh: Reserved 80h~FFh: Vendor Defined Function

Note: The Audio Function Group (NID=01h) supports this parameter.

7.1.4. Parameter – Audio Function Capabilities (Verb ID=F00h, Parameter ID=08h)

Table 20. Parameter – Audio Function Capabilities (Verb ID=F00h, Parameter ID=08h)

Codec Response Format

Bit	Description
31:17	Reserved. Read as 0's.
16	Beep Generator, Read as 1. A '1' indicates the presence of an integrated Beep generator within the Audio Function Group.
15:12	Reserved. Read as 0's.
11:8	Input Delay. Read as 0xF.
7:4	Reserved. Read as 0's.
3:0	Output Delay. Read as 0xF.

Note: The Audio Function Group (NID=01h) supports this parameter.

7.1.5. Parameter – Audio Widget Capabilities (Verb ID=F00h, Parameter ID=09h)

Table 21. Parameter – Audio Widget Capabilities (Verb ID=F00h, Parameter ID=09h)

Codec Response Format

Bit	Description
31:24	Reserved. Read as 0's.
23:20	Widget Type. 0h: Audio Output 1h: Audio Input 2h: Mixer 3h: Selector 4h: Pin Complex 5h: Power Widget 6h: Volume Knob Widget 7h~Eh: Reserved Fh: Vendor defined audio widget
19:16	Delay. Samples delayed between the HDA link and widgets.
15:11	Reserved. Read as 0's.
10	Power Control. 0: Power state control is not supported on this widget 1: Power state is supported on this widget
9	Digital. 0: An analog input or output converter 1: A widget translating digital data between the HDA link and digital I/O (SPDIF, I ² S, etc.)
8	ConnList. Connection List. 0: Connected to HDA link. No Connection List Entry should be queried 1: Connection List Entry must be queried
7	UnsolCap. Unsolicited Capable. 0: Unsolicited response is not supported 1: Unsolicited response is supported
6	ProcWidget. Processing Widget. 0: No processing control 1: Processing control is supported
5	Reserved. Read as 0.
4	Format Override.
3	AmpParOvr, AMP Param Override.
2	OutAmpPre. Out AMP Present.
1	InAmpPre. In AMP Present.
0	Stereo. 0: Mono Widget 1: Stereo Widget

7.1.6. Parameter – Supported PCM Size, Rates (Verb ID=F00h, Parameter ID=0Ah)

Parameters here provide default information about formats. Individual converters have their own parameters to provide supported formats if their ‘Format Override’ bit is set.

Table 22. Parameter – Supported PCM Size, Rates (Verb ID=F00h, Parameter ID=0Ah)

Codec Response Format

Bit	Description
31:21	Reserved. Read as 0's.
20	B32. 32-bit audio format support. 0: Not supported 1: Supported
19	B24. 24-bit audio format support. 0: Not supported 1: Supported
18	B20. 20-bit audio format support. 0: Not supported 1: Supported
17	B16. 16-bit audio format support. 0: Not supported 1: Supported
16	B8. 24-bit audio format support. 0: Not supported 1: Supported
15:12	Reserved. Read as 0's.
11	R12. 384kHz (=8×48kHz) rate support. 0: Not supported 1: Supported
10	R11. 192kHz (=4×48kHz) rate support. 0: Not supported 1: Supported
9	R10. 176.4kHz (=4×44.1kHz) rate support. 0: Not supported 1: Supported
8	R9. 96kHz (=2×48kHz) rate support. 0: Not supported 1: Supported
7	R8. 88.2kHz (=2×44.1kHz) rate support. 0: Not supported 1: Supported
6	R7. 48kHz rate support. 0: Not supported 1: Supported
5	R6. 44.1kHz rate support. 0: Not supported 1: Supported
4	R5. 32kHz (=2/3×48kHz) rate support. 0: Not supported 1: Supported
3	R4. 22.05kHz (=1/2×44.1kHz) rate support. 0: Not supported 1: Supported
2	R3. 16kHz (=1/3×48kHz) rate support. 0: Not supported 1: Supported
1	R2. 11.025kHz (=1/4×44.1kHz) rate support. 0: Not supported 1: Supported
0	R1. 8kHz (=1/6×48kHz) rate support. 0: Not supported 1: Supported

7.1.7. Parameter – Supported Stream Formats (Verb ID=F00h, Parameter ID=0Bh)

Parameters in this node only provide default information for audio function groups. Individual converters have their own parameters to provide supported formats if the ‘Format Override’ bit is set.

Table 23. Parameter – Supported Stream Formats (Verb ID=F00h, Parameter ID=0Bh)

Codec Response Format

Bit	Description
31:3	Reserved. Read as 0's.
2	AC3. 0: Not supported 1: Supported
1	Float32. 0: Not supported 1: Supported
0	PCM. 0: Not supported 1: Supported

Note: Input converters and output converters support this parameter.

7.1.8. Parameter – Pin Capabilities (Verb ID=F00h, Parameter ID=0Ch)

The Pin Capabilities parameter returns a bit field describing the capabilities of the Pin Complex widget.

Table 24. Parameter – Pin Capabilities (Verb ID=F00h, Parameter ID=0Ch)

Codec Response Format

Bit	Description														
31:16	Reserved. Read as 0's														
15:8	VREF Control Capability. ‘1’ in corresponding bit field indicates signal levels of associated Vrefout are specified as a percentage of ALDO-CAP. <table border="1" style="margin-left: 20px;"> <thead> <tr> <th>7:6</th> <th>5</th> <th>4</th> <th>3</th> <th>2</th> <th>1</th> <th>0</th> </tr> </thead> <tbody> <tr> <td>Reserved</td> <td>100%</td> <td>80%</td> <td>Reserved</td> <td>Ground</td> <td>50%</td> <td>Hi-Z</td> </tr> </tbody> </table>	7:6	5	4	3	2	1	0	Reserved	100%	80%	Reserved	Ground	50%	Hi-Z
7:6	5	4	3	2	1	0									
Reserved	100%	80%	Reserved	Ground	50%	Hi-Z									
7	L-R Swap. Indicates the capability of swapping the left and right.														
6	Balanced I/O Pin. ‘1’ indicates this pin complex has balanced pins.														
5	Input Capable. ‘1’ indicates this pin complex supports input.														
4	Output Capable. ‘1’ indicates this pin complex supports output.														
3	Headphone Drive Capable. ‘1’ indicates this pin complex has an amplifier to drive a headphone.														
2	Presence Detect Capable. ‘1’ indicates this pin complex can detect whether there is anything plugged in.														
1	Trigger Required. ‘1’ indicates whether a software trigger is required for an impedance measurement.														
0	Impedance Sense Capable. ‘1’ indicates this pin complex can perform analog sense on the attached device to determine its type.														

Note: Only Pin Complex widgets support this parameter.

7.1.9. Parameter – Amplifier Capabilities (Verb ID=F00h, Input Amplifier Parameter ID=0Dh)

Parameters in this node provide audio function group default information. Individual converters have their own parameters to provide amplifier capabilities if the ‘AMP Param Override’ bit is set.

Table 25. Parameter – Amplifier Capabilities (Verb ID=F00h, Input Amplifier Parameter ID=0Dh)

Codec Response Format

Bit	Description
31	(Input) Mute Capable.
30:23	Reserved. Read as 0.
22:16	Step Size. Indicates the size of each step in the gain range. Each step may be 0~32dB, specified in 0.25dB steps. ‘0’ indicates a step of 0.25dB. ‘127’ indicates a step of 32dB.
15	Reserved. Read as 0.
14:8	Number of Steps. Indicates the number of steps in the gain range. ‘0’ means the gain is fixed.
7	Reserved. Read as 0.
6:0	Offset. Indicates which step is 0dB.

7.1.10. Parameter – Amplifier Capabilities (Verb ID=F00h, Output Amplifier Parameter ID=12h)

Parameters in this node provide audio function group default information. Individual converters have their own parameters to provide amplifier capabilities if the ‘AMP Param Override’ bit is set.

Table 26. Parameter – Amplifier Capabilities (Verb ID=F00h, Output Amplifier Parameter ID=12h)

Codec Response Format

Bit	Description
31	(Output) Mute Capable.
30:23	Reserved. Read as 0.
22:16	Step Size. Indicates the size of each step in the gain range. Each step may be 0~32dB, specified in 0.25dB steps. ‘0’ indicates a step of 0.25dB. ‘127’ indicates a step of 32dB.
15	Reserved. Read as 0.
14:8	Number of Steps. Indicates the number of steps in the gain range. ‘0’ means the gain is fixed.
7	Reserved. Read as 0.
6:0	Offset. Indicates which step is 0dB.

7.1.11. Parameter – Connect List Length (Verb ID=F00h, Parameter ID=0Eh)

Parameters in this node provide audio function widget connection information.

Table 27. Parameter – Connect List Length (Verb ID=F00h, Parameter ID=0Eh)

Codec Response Format

Bit	Description
31:8	Reserved. Read as 0.
7	Short Form. 0: Short form 1: Long form
6:0	Connect List Length. Indicates the number of inputs connected to a widget. If the Connect List Length is 1, there is only one input, and there is no Connection Select Control (not a MUX widget).

7.1.12. Parameter – Supported Power States (Verb ID=F00h, Parameter ID=0Fh)

Table 28. Parameter – Supported Power States (Verb ID=F00h, Parameter ID=0Fh)

Codec Response Format

Bit	Description
31	Extended Power States Supported (EPSS). 1: Extended power states EPSS is supported
30	CLKSTOP. 1: D3 mode operates even there is no BITCLK presents on the link
29:4	Reserved. Read as 0's.
3	D3Sup. 1: Power state D3 is supported
2	D2Sup. 1: Power state D2 is supported
1	D1Sup. 1: Power state D1 is supported
0	D0Sup. 1: Power state D0 is supported

7.1.13. Parameter – Processing Capabilities (Verb ID=F00h, Parameter ID=10h)

Table 29. Parameter – Processing Capabilities (Verb ID=F00h, Parameter ID=10h)

Codec Response Format

Bit	Description
31:16	Reserved. Read as 0's.
15:8	NumCoeff. Number of Coefficient.
7:1	Reserved. Read as 0's.
0	Benign. 0: Processing unit is not linear and time invariant 1: Processing unit is linear and time invariant

7.1.14. Parameter – GPIO Capabilities (Verb ID=F00h, Parameter ID=11h)

Table 30. Parameter – GPIO Capabilities (Verb ID=F00h, Parameter ID=11h)

Codec Response Format

Bit	Description
31	GPIWake=0. The CM9881 does not support GPIO wake up function.
30	GPIUnsol=1. The CM9881 supports GPIO unsolicited response.
29:24	Reserved. Read as 0's.
23:16	NumGPIs=00h. No GPI pin is supported.
15:8	NumGPOs=00h. No GPO pin is supported.
7:0	NumGPIOs=01h. Two GPIO pins are supported.

7.1.15. Parameter – Volume Knob Capabilities (Verb ID=F00h, Parameter ID=13h)

Table 31. Parameter – Volume Knob Capabilities (Verb ID=F00h, Parameter ID=13h)

Codec Response Format for NID=21h (Volume Control Knob)

Bit	Description
31:8	Reserved. Read as 0s.
7	Delta. Read as 0. 0: Software will not modify the volume in Volume Control Knob 1: Software can write a base volume to the Volume Control Knob
6:0	NumSteps. The total number of steps in the range of the Volume Control Knob (NID=21h)

Note: The Volume Control knob (NID=21h) supports this parameter.

7.2. Verb – Get Connection Select Control (Verb ID=F01h)

Table 32. Verb – Get Connection Select Control (Verb ID=F01h)

Get Command Format				Codec Response Format
Bit [31:28]	Bit [27:20]	Bit [19:8]	Payload Bit [7:0]	Response [31:0]
CAd=X	Node ID=Xh	Verb ID=F01h	0's	Bit[7:0] are Connection Index

Codec Response for Analog Port-A/D/G (NID=14h, 15h and 16h)

Bit	Description
31:8	0's.
7:0	Connection Index Current Settings (Default Value is 00h). 00h: Sum Widget NID=0Ch 01h: Sum Widget NID=0Dh 02h: Sum Widget NID=0Eh 03h: Sum Widget NID=0Fh Other: Reserved

Codec Response for Analog Port-H/C/E/I (NID=17h, 1Ah, 1Bh and 21h)

Bit	Description
31:8	0's.
7:0	Connection Index Current Settings (Default Value is 00h). 00h: Sum Widget NID=0Ch 01h: Sum Widget NID=0Dh 02h: Sum Widget NID=0Eh Other: Reserved

Codec Response for Other NID

Bit	Description
31:0	Not Supported (Returns 00000000h).

7.3. Verb – Set Connection Select (Verb ID=701h)

Table 33. Verb – Set Connection Select (Verb ID=701h)

Set Command Format				Codec Response Format
Bit [31:28]	Bit [27:20]	Bit [19:8]	Payload Bit [7:0]	Response [31:0]
CAd=X	Node ID=Xh	Verb ID=701h	Select Index [7:0]	0's for All Nodes

7.4. Verb – Get Connection List Entry (Verb ID=F02h)

Table 34. Verb – Get Connection List Entry (Verb ID=F02h)

Get Command Format				Codec Response Format
Bit [31:28]	Bit [27:20]	Bit [19:8]	Payload Bit [7:0]	Response [31:0]
CAd=X	Node ID=Xh	Verb ID=F02h	Offset Index - N[7:0]	32-bit Response

Codec Response for NID=08h (LINE ADC)

Bit	Description
31:8	Connection List Entry (N+3), (N+2), and (N+1). Returns 000000h.
7:0	Connection List Entry (N). Returns 23h (Sum Widget) for N=0~3. Returns 00h for N>3.

Codec Response for NID=09h (MIX ADC)

Bit	Description
15:8	Connection List Entry (N+3), (N+2), and (N+1). Returns 000000h.
7:0	Connection List Entry (N). Returns 22h (Sum Widget) for N=0~3. Returns 00h for N>3.

Codec Response for NID=0Bh (Mixer)

Bit	Description
31:24	Connection List Entry (N+3). Returns 1Bh (Pin Complex – LINE2) for N=0~3. Returns 16h (Pin Complex – CEN/LFE) for N=4~7. Returns 00h for N>7.
23:16	Connection List Entry (N+2). Returns 1Ah (Pin Complex – LINE1) for N=0~3. Returns 15h (Pin Complex – SURR) for N=4~7. Returns 00h for N>7.
15:8	Connection List Entry (N+1). Returns 19h (Pin Complex – MIC2) for N=0~3. Returns 14h (Pin Complex – FRONT) for N=4~7. Returns 00h for N>7.
7:0	Connection List Entry (N). Returns 18h (Pin Complex – MIC1) for N=0~3. Returns 1Dh (Pin Complex – PCBEEP) for N=4~7. Returns 00h for N>7.

Codec Response for NID=0Ch (Front Sum)

Bit	Description
31:24	Connection List Entry (N). Returns 00h.
23:16	Connection List Entry (N+2). Returns 00h.
15:8	Connection List Entry (N+1). Returns 0Bh (Mixer) for N=0~3. Returns 00h for N>3.

7:0	Connection List Entry (N). Returns 02h (Front DAC) for N=0~3. Returns 00h for N>3.
-----	--

Codec Response for NID=0Dh (Surround Sum)

Bit	Description
31:24	Connection List Entry (N). Returns 00h.
23:16	Connection List Entry (N+2). Returns 00h.
15:8	Connection List Entry (N+1). Returns 0Bh (Mixer) for N=0~3. Returns 00h for N>3.
7:0	Connection List Entry (N). Returns 03h (Surround DAC) for N=0~3. Returns 00h for N>3.

Codec Response for NID=0Eh (Cen/LFE Sum)

Bit	Description
31:24	Connection List Entry (N). Returns 00h.
23:16	Connection List Entry (N+2). Returns 00h.
15:8	Connection List Entry (N+1). Returns 0Bh (Mixer) for N=0~3. Returns 00h for N>3.
7:0	Connection List Entry (N). Returns 04h (Cen/LFE DAC) for N=0~3. Returns 00h for N>3.

Codec Response for NID=0Fh (Side-Surr Sum)

Bit	Description
31:24	Connection List Entry (N). Returns 00h.
23:16	Connection List Entry (N+2). Returns 00h.
15:8	Connection List Entry (N+1). Returns 0Bh (Mixer) for N=0~3. Returns 00h for N>3.
7:0	Connection List Entry (N). Returns 05h (Front DAC) for N=0~3. Returns 00h for N>3.

Codec Response for NID=14h (Port-D)

Bit	Description
31:24	Connection List Entry (N+3). Returns 0Fh (Sum Widget NID=0Fh) for N=0~3. Returns 00h for N>3.
23:16	Connection List Entry (N+2). Returns 0Eh (Sum Widget NID=0Eh) for N=0~3. Returns 00h for N>3.
15:8	Connection List Entry (N+1). Returns 0Dh (Sum Widget NID=0Dh) for N=0~3. Returns 00h for N>3.
7:0	Connection List Entry (N). Returns 0Ch (Sum Widget NID=0Ch) for N=0~3. Returns 00h for N>3.

Codec Response for NID=15h (Port-A)

Bit	Description
31:24	Connection List Entry (N+3). Returns 0Fh (Sum Widget NID=0Fh) for N=0~3. Returns 00h for N>3.
23:16	Connection List Entry (N+2). Returns 0Eh (Sum Widget NID=0Eh) for N=0~3. Returns 00h for N>3.
15:8	Connection List Entry (N+1). Returns 0Dh (Sum Widget NID=0Dh) for N=0~3. Returns 00h for N>3.
7:0	Connection List Entry (N). Returns 0Ch (Sum Widget NID=0Ch) for N=0~3. Returns 00h for N>3.

Codec Response for NID=16h (Port-G)

Bit	Description
31:24	Connection List Entry (N+3). Returns 0Fh (Sum Widget NID=0Fh) for N=0~3. Returns 00h for N>3.
23:16	Connection List Entry (N+2). Returns 0Eh (Sum Widget NID=0Eh) for N=0~3. Returns 00h for N>3.
15:8	Connection List Entry (N+1). Returns 0Dh (Sum Widget NID=0Dh) for N=0~3. Returns 00h for N>3.
7:0	Connection List Entry (N). Returns 0Ch (Sum Widget NID=0Ch) for N=0~3. Returns 00h for N>3.

Codec Response for NID=17h (Port-H)

Bit	Description
31:24	Connection List Entry (N+3). Returns 00h.
23:16	Connection List Entry (N+2). Returns 0Eh (Sum Widget NID=0Eh) for N=0~3. Returns 00h for N>3.
15:8	Connection List Entry (N+1). Returns 0Dh (Sum Widget NID=0Dh) for N=0~3. Returns 00h for N>3.
7:0	Connection List Entry (N). Returns 0Ch (Sum Widget NID=0Ch) for N=0~3. Returns 00h for N>3.

Codec Response for NID=18h (Port-B)

Bit	Description
31:24	Connection List Entry (N+3). Returns 00h.
23:16	Connection List Entry (N+3). Returns 00h.
15:8	Connection List Entry (N+3). Returns 00h.
7:0	Connection List Entry (N+2). Returns 0Eh (Sum Widget NID=0Eh) for N=0~3. Returns 00h for N>3.

Codec Response for NID=1Ah (Port-C)

Bit	Description
31:24	Connection List Entry (N+3). Returns 00h.
23:16	Connection List Entry (N+2). Returns 0Eh (Sum Widget NID=0Eh) for N=0~3. Returns 00h for N>3.
15:8	Connection List Entry (N+1). Returns 0Dh (Sum Widget NID=0Dh) for N=0~3. Returns 00h for N>3.
7:0	Connection List Entry (N). Returns 0Ch (Sum Widget NID=0Ch) for N=0~3. Returns 00h for N>3.

Codec Response for NID=1Bh (Port-E)

Bit	Description
31:24	Connection List Entry (N+3). Returns 00h.
23:16	Connection List Entry (N+2). Returns 0Eh (Sum Widget NID=0Eh) for N=0~3. Returns 00h for N>3.
15:8	Connection List Entry (N+1). Returns 0Dh (Sum Widget NID=0Dh) for N=0~3. Returns 00h for N>3.
7:0	Connection List Entry (N). Returns 0Ch (Sum Widget NID=0Ch) for N=0~3. Returns 00h for N>3.

Codec Response for NID=1Eh (Pin Widget: SPDIF-OUT)

Bit	Description
31:16	Connection List Entry (N+3) and (N+2). Returns 0000h.
15:8	Connection List Entry (N+1). Returns 00h.
7:0	Connection List Entry (N). Returns 06h (SPDIF-OUT converter) for N=0~3. Returns 00h for N>3.

Codec Response for NID=21h (Port-I)

Bit	Description
31:24	Connection List Entry (N+3) Returns 00h.
23:16	Connection List Entry (N+2). Returns 0Eh (Sum Widget NID=0Eh) for N=0~3. Returns 00h for N>3..
15:8	Connection List Entry (N+1). Returns 0Dh (Sum Widget NID=0Dh) for N=0~3. Returns 00h for N>3.
7:0	Connection List Entry (N). Returns 0Ch (Sum Widget NID=0Ch) for N=0~3. Returns 00h for N>3.

Codec Response for NID=22h (Sum Widget before ADC 09h)

Bit	Description
31:24	Connection List Entry (N+3). Returns 1Bh (Pin Complex – LINE2) for N=0~3. Returns 16h (Pin Complex – CEN/LFE) for N=4~7. Returns 00h for N>7.
23:16	Connection List Entry (N+2). Returns 1Ah (Pin Complex – LINE1) for N=0~3. Returns 15h (Pin Complex – SURR) for N=4~7. Returns 00h for N>7.
15:8	Connection List Entry (N+1). Returns 19h (Pin Complex – MIC2) for N=0~3. Returns 14h (Pin Complex – FRONT) for N=4~7. Returns 00h for N>7.
7:0	Connection List Entry (N). Returns 18h (Pin Complex – MIC1) for N=0~3. Returns 1Dh (Pin Complex – PCBEEP) for N=4~7. Returns 0Bh (Pin Complex – MIXER) for N=8~11. Returns 00h for N>11.

Codec Response for NID=23h (Sum Widget before ADC 08h)

Bit	Description
31:24	Connection List Entry (N+3). Returns 1Bh (Pin Complex – LINE2) for N=0~3. Returns 16h (Pin Complex – CEN/LFE) for N=4~7. Returns 00h for N>7.
23:16	Connection List Entry (N+2). Returns 1Ah (Pin Complex – LINE1) for N=0~3. Returns 15h (Pin Complex – SURR) for N=4~7. Returns 00h for N>7.
15:8	Connection List Entry (N+1). Returns 19h (Pin Complex – MIC2) for N=0~3. Returns 14h (Pin Complex – FRONT) for N=4~7. Returns 00h for N>7.
7:0	Connection List Entry (N). Returns 18h (Pin Complex – MIC1) for N=0~3. Returns 1Dh (Pin Complex – PCBEEP) for N=4~7. Returns 0Bh (Pin Complex – MIXER) for N=8~11. Returns 00h for N>11.

Codec Response for Other NID

Bit	Description
31:0	Not Supported (Returns 00000000h).

7.5. Verb – Get Processing State (Verb ID=F03h)

Table 35. Verb – Get Processing State (Verb ID=F03h)

Get Command Format

Bit [31:28]	Bit [27:20]	Bit [19:8]	Payload Bit [7:0]
CAd=X	Node ID=Xh	Verb ID=F03h	0's

Codec Response Format

Response [31:0]
32-bit Response

Codec Response for All NID

Bit	Description
31:0	Not Supported (Returns 00000000h).

7.6. Verb – Set Processing State (Verb ID=703h)

Table 36. Verb – Set Processing State (Verb ID=703h)

Set Command Format

Bit [31:28]	Bit [27:20]	Bit [19:8]	Payload Bit [7:0]
CAd=X	Node ID=Xh	Verb ID=703h	Processing State [7:0]

Codec Response Format

Response [31:0]
0's for All Nodes

Codec Response for All NID

Bit	Description
31:0	0's.

7.7. Verb – Get Coefficient Index (Verb ID=Dh)

Table 37. Verb – Get Coefficient Index (Verb ID=Dh)

Get Command Format

Bit [31:28]	Bit [27:20]	Bit [19:16]	Payload Bit [15:0]
CAd=X	Node ID=20h	Verb ID=Dh	0's

Codec Response Format

Response [31:0]
Bit [15:0] are Coefficient Index

Codec Response for NID=20h (Cmedia Defined Registers)

Bit	Description
31:16	Reserved. Read as 0's.
15:0	Coefficient Index.

Codec Response for Other NID

Bit	Description
31:0	Not Supported (Returns 00000000h).

7.8. Verb – Set Coefficient Index (Verb ID=5h)

Table 38. Verb – Set Coefficient Index (Verb ID=5h)

Set Command Format				Codec Response Format
Bit [31:28]	Bit [27:20]	Bit [19:16]	Payload Bit [15:0]	Response [31:0]
CAd=X	Node ID=Xh	Verb ID=5h	Coefficient Index [15:0]	0's for All Nodes

Codec Response for All NID

Bit	Description
31:0	0's.

7.9. Verb – Get Processing Coefficient (Verb ID=Ch)

Table 39. Verb – Get Processing Coefficient (Verb ID=Ch)

Get Command Format				Codec Response Format
Bit [31:28]	Bit [27:20]	Bit [19:16]	Payload Bit [15:0]	Response [31:0]
CAd=X	Node ID=20h	Verb ID=Ch	0's	Processing Coefficient [15:0]

Codec Response for NID=20h (Cmedia Defined Registers)

Bit	Description
31:16	Reserved. Read as 0's.
15:0	Processing Coefficient.

Codec Response for Other NID

Bit	Description
31:0	Not Supported (Returns 00000000h).

7.10. Verb – Set Processing Coefficient (Verb ID=4h)

Table 40. Verb – Set Processing Coefficient (Verb ID=4h)

Set Command Format				Codec Response Format
Bit [31:28]	Bit [27:20]	Bit [19:16]	Payload Bit [15:0]	Response [31:0]
CAd=X	Node ID=Xh	Verb ID=4h	Coefficient [15:0]	0's for All Nodes

Codec Response for All NID

Bit	Description
31:0	0's.

7.11. Verb – Get Amplifier Gain (Verb ID=Bh)

This verb is used to get gain/attenuation settings from each widget.

Table 41. Verb – Get Amplifier Gain (Verb ID=Bh)

Get Command Format

Bit [31:28]	Bit [27:20]	Bit [19:16]	Payload Bit [15:0]
CAd=X	Node ID=Xh	Verb ID=Bh	'Get' Payload [15:0]

Codec Response Format

Response [31:0]
Bit[7:0] are Responsible for 'Get'

'Get' Payload in Command Bit[15:0]

Bit	Description
15	Get Input/Output. 0: Input amplifier gain is requested 1: Output amplifier gain is requested
14	Reserved. Read as 0.
13	Get Left/Right. 0: Right amplifier gain is requested 1: Left amplifier gain is requested
12:4	Reserved. Read as 0's.
3:0	Index[3:0] for Input Source. Select amplifier for this converter. If a widget has no multiple input sources, the index will be ignored.

Codec Response for 08h (LINE ADC) and 09h (MIX ADC)

Bit	Description
31:8	0's.
7	Bit 15 is 0 in 'Get Amplifier Gain'. Input Amplifier Mute. 0: Unmute 1: Mute Bit 15 is 1 in 'Get Amplifier Gain'. Read as 0 (No Output Amplifier Mute).
6:0	Bit 15 is 0 in 'Get Amplifier Gain'. Input Amplifier Gain [6:0]. 7-bit step value (0~46) specifying the volume from -17.25dB~+30dB in 0.75dB steps. Bit 15 is 1 in 'Get Amplifier Gain'. Read as 0's (No Output Amplifier Mute).

Codec Response for NID=0Bh (MIXER Sum Widget)

Bit	Description
31:8	0's.
7	Bit 15 is 0 in 'Get Amplifier Gain'. Input Amplifier Mute. 0: Unmute 1: Mute (Default for all Index) Bit 15 is 1 in 'Get Amplifier Gain'. Read as 0 (No Output Amplifier Mute).
6:0	Bit 15 is 0 in 'Get Amplifier Gain'. Input Amplifier Gain [6:0]. 7-bit step value (0~31) specifying the volume from -34.5dB~+12dB in 1.5dB steps. Bit 15 is 1 in 'Get Amplifier Gain'. Read as 0's (No Output Amplifier Mute).

Codec Response for NID=0Ch~0Eh and 0Fh (Sum Widget: Front, Surr, Cen/LFE, SIDESURR Sum)

Bit	Description
31:8	0's.
7	Bit 15 is 0 in 'Get Amplifier Gain'. Input Amplifier Mute. 0: Unmute 1: Mute Bit 15 is 1 in 'Get Amplifier Gain'. Read as 0 (No Output Amplifier Mute).
6:0	Bit 15 is 0 in 'Get Amplifier Gain'. Read as 0 (No Input Amplifier Gain). Bit 15 is 1 in 'Get Amplifier Gain'. Read as 0 (No Output Amplifier Gain).

Codec Response for NID=02h ~ 04h and 05h (DAC Widget: Front, Surr, Cen/LFE, SIDESURR DAC)

Bit	Description
31:8	0's.
7	Bit 15 is 0 in 'Get Amplifier Gain. Read as 0 (No Output Amplifier Mute). Bit 15 is 1 in 'Get Amplifier Gain. Read as 0 (No Output Amplifier Mute).
6:0	Bit 15 is 0 in 'Get Amplifier Gain. Read as 0's (No Output Amplifier Mute). Bit 15 is 1 in 'Get Amplifier Gain. Output Amplifier Gain [6:0]. 7-bit step value (0~127) specifying the volume from -65.25dB~0dB in 0.75dB steps.

Codec Response for NID=14h~16h (Pin Complex: Front/Surr/CenLFE)

Bit	Description
31:8	0's.
7	Bit 15 is 0 in 'Get Amplifier Gain'. Read as 0. Bit 15 is 1 in 'Get Amplifier Gain'. Output Amplifier Mute. 0: Unmute 1: Mute (NID=14h~17h, Default=1)
6:0	Bit 15 is 0 in 'Get Amplifier Gain'. Read as 0's. Bit 15 is 1 in 'Get Amplifier Gain'. Read as 0 (No Output Amplifier Gain).

Codec Response for NID=18h~1Bh (Pin Complex: MIC1/MIC2/LINE1/LINE2)

Bit	Description
31:8	0's.
7	Bit 15 is 0 in 'Get Amplifier Gain. Read as 0. Bit 15 is 1 in 'Get Amplifier Gain. Output Amplifier Mute: 0: Unmute 1: Mute (NID=18h~1Bh, Default=1)
6:0	Bit 15 is 0 in 'Get Amplifier Gain. Input Amplifier Gain [6:0]. 7-bit step value (0~3) specifying the volume from 0dB~30dB in 10dB steps. Bit 15 is 1 in 'Get Amplifier Gain. Read as 0 (No Output Amplifier Gain).

Codec Response for NID=22h and 23h (Sum Widget)

Bit	Description
31:8	0's.
7	Bit 15 is 0 in 'Get Amplifier Gain. Input Amplifier Mute: 0: Unmute; 1: Mute Bit 15 is 1 in 'Get Amplifier Gain. Read as 0 (No Output Amplifier Mute).
6:0	Bit 15 is 0 in 'Get Amplifier Gain. Read as 0 (No Input Amplifier Gain). Bit 15 is 1 in 'Get Amplifier Gain. Read as 0 (No Input Amplifier Gain).

Codec Response to Other NID

Bit	Description
31:0	Not Supported (Returns 00000000h).

7.12. Verb – Set Amplifier Gain (Verb ID=3h)

This verb is used to set amplifier gain/attenuation in each widget.

Table 42. Verb – Set Amplifier Gain (Verb ID=3h)
Set Command Format

Bit [31:28]	Bit [27:20]	Bit [19:16]	Payload Bit [15:0]
CAd=X	Node ID=Xh	Verb ID=3h	'Set' Payload [15:0]

Codec Response Format

Response [31:0]
0's for All Nodes

'Set' Payload in Command Bit[15:0]

Bit	Description
15	Set Output Amp. '1' indicates output amplifier gain will be set.
14	Set Input Amp. '1' indicates input amplifier gain will be set.
13	Set Left Amp. '1' indicates left amplifier gain will be set.
12	Set Right Amp. '1' indicates right amplifier gain will be set.
11:8	Index Offset (for Input Amplifiers on Sum Widgets and Selector Widgets). 5 bits index offset in connection list is used to select which input gain will be set on a Sum or a Selector widget. The index is ignored if the node is not a Sum or a Selector widget, or the 'Set Input Amp' bit is not set.
7	Mute. 0: Unmute 1: Mute (-∞gain)
6:0	Gain[6:0]. A 7-bit step value specifying the amplifier gain.

7.13. Verb – Get Converter Format (Verb ID=Ah)

Table 43. Verb – Get Converter Format (Verb ID=Ah)

Get Command Format

Bit [31:28]	Bit [27:20]	Bit [19:16]	Payload Bit [15:0]
CAd=X	Node ID=Xh	Verb ID=Ah	0's

Codec Response Format

Response [31:0]
Bit[15:0] are Converter Format

Codec Response for NID=02h~06h (Output Converters: Front, Surr, Cen/LFE, Side-Surr, SPDIF-OUT).

Codec Response for NID=08h~09h (Input Converters: LINE, MIX ADC)

Bit	Description
31:16	Reserved. Read as 0.
15	Stream Type (TYPE). 0: PCM 1: Non-PCM
14	Sample Base Rate (BASE). 0: 48kHz 1: 44.1kHz
13:11	Sample Base Rate Multiple (MULT). 000b: ×1 001b: ×2 010b: ×3 011b: ×4 100b~111b: Reserved
10:8	Sample Base Rate Divisor (DIV). 000b: /1 001b: /2 010b: /3 011b: /4 100b: /5 101b: /6 110b: /7 111b: /8
7	Reserved. Read as 0.
6:4	Bits per Sample (BITS). 000b: 8 bits 001b: 16 bits 010b: 20 bits 011b: 24 bits 100b: 32 bits 101b~111b: Reserved
3:0	Number of Channels. 0: 1 channel 1: 2 channels 2: 3 channels 15: 16 channels

7.14. Verb – Set Converter Format (Verb ID=2h)

Table 44. Verb – Set Converter Format (Verb ID=2h)

Set Command Format

Codec Response Format

Bit [31:28]	Bit [27:20]	Bit [19:16]	Payload Bit [15:0]
CAd=X	Node ID=Xh	Verb ID=2h	Set Format [15:0]

Response [31:0]
0's for All Nodes

'Set' Payload in Command Bit[15:0]

Bit	Description
31:16	Reserved. Read as 0.
15	Stream Type (TYPE). 0: PCM 1: Non-PCM
14	Sample Base Rate (BASE). 0: 48kHz 1: 44.1kHz
13:11	Sample Base Rate Multiple (MULT). 000b: ×1 001b: ×2 010b: ×3 011b: ×4 100b~111b: Reserved
10:8	Sample Base Rate Divisor (DIV). 000b: /1 001b: /2 010b: /3 011b: /4 100b: /5 101b: /6 110b: /7 111b: /8
7	Reserved. Read as 0.
6:4	Bits per Sample (BITS). 000b: 8 bits 001b: 16 bits 010b: 20 bits 011b: 24 bits 100b: 32 bits 101b~111b: Reserved
3:0	Number of Channels. 0: 1 channel 1: 2 channels 2: 3 channels 15: 16 channels

7.15. Verb – Get Power State (Verb ID=F05h)

Table 45. Verb – Get Power State (Verb ID=F05h)

Get Command Format				Codec Response Format
Bit [31:28]	Bit [27:20]	Bit [19:8]	Payload Bit [7:0]	Response [31:0]
CAd=X	Node ID=01h	Verb ID=F05h	0's	Power State [7:0]

Codec Response for NID=01h (Audio Function Group)

Codec Response for NID=02h~05h, 08h, 09h (Audio Input/Output Converter)

Codec Response for NID=14h~1Eh (Pin Widget)

Codec Response for NID=06h (Audio Output Converter)

Bit	Description
31:6	Reserved. Read as 0's.
5:4	PS-Act. Actual Power State [1:0]. 00: Power state is D0 01: Power state is D1 10: Power state is D2 11: Power state is D3 PS-Act indicates the actual power state of the referenced node. For Audio Function Group nodes (NID=01h), PS-Act is always equal to PS-Set.
3:2	Reserved. Read as 0's.
1:0	PS-Set. Set Power State [1:0]. 00: Power state is D0 01: Power state is D1 10: Power state is D2 11: Power state is D3 PS-Set controls the current power setting of the referenced node.

Codec Response for Other NID

Bit	Description
31:0	Not Supported (Returns 00000000h).

7.16. Verb – Set Power State (Verb ID=705h)

Table 46. Verb – Set Power State (Verb ID=705h)

Set Command Format				Codec Response Format
Bit [31:28]	Bit [27:20]	Bit [19:8]	Payload Bit [7:0]	Response [31:0]
CAd=X	Node ID=01h	Verb ID=705h	Power State [7:0]	0's for All Nodes

'Power State' in Command Bit[7:0]

Bit	Description
7:6	Reserved. Read as 0's.
5:4	PS-Act. Actual Power State [1:0]. 00: Power state is D0 01: Power state is D1 10: Power state is D2 11: Power state is D3 PS-Act indicates the actual power state of the referenced node.
3:2	Reserved. Read as 0's.
1:0	PS-Set. Set Power State [1:0]. 00: Power state is D0 01: Power state is D1 10: Power state is D2 11: Power state is D3

7.17. Verb – Get Converter Stream, Channel (Verb ID=F06h)

Table 47. Verb – Get Converter Stream, Channel (Verb ID=F06h)

Get Command Format				Codec Response Format
Bit [31:28]	Bit [27:20]	Bit [19:8]	Payload Bit [7:0]	Response [31:0]
CAd=X	Node ID=Xh	Verb ID=F06h	0's	Stream & Channel [7:0]

Codec Response for NID=02h~05h, 06h (Output Converters: Front, Surr, Cen/LFE, Side-Surr DAC, SPDIF-OUT)

Codec Response for NID=08h~09h (Input Converters: LINE ADC, MIX ADC)

Bit	Description
31:8	Reserved. Read as 0's.
7:4	Stream[3:0]. The link stream used by the converter. 0000b is stream 0, 0001b is stream 1, etc.
3:0	Channel[3:0]. The lowest channel used by the converter. A stereo converter will use the set channel n as well as n+1 for its left and right channel.

Codec Response for Other NID

Bit	Description
31:0	Not Supported (Returns 00000000h).

7.18. Verb – Set Converter Stream, Channel (Verb ID=706h)

Table 48. Verb – Set Converter Stream, Channel (Verb ID=706h)

Set Command Format				Codec Response Format
Bit [31:28]	Bit [27:20]	Bit [19:8]	Payload Bit [7:0]	Response [31:0]
CAd=X	Node ID=Xh	Verb ID=706h	Stream & Channel [7:0]	0's for All Nodes

'Stream and Channel' in Command Bit[7:0]

Bit	Description
31:8	Reserved. Read as 0's.
7:4	Set Stream[3:0]. The link stream used by the converter. 0000b is stream 0, 0001b is stream 1, etc.
1:0	Set Channel[3:0]. The lowest channel used by the converter. A stereo converter will use the set channel n as well as n+1 for its left and right channel.

Note: This verb assigns stream and channel for output converters (NID=02h~06h, 25h, 10h) and input converters (NID=08h~0Ah). Other widgets will ignore this verb.

7.22. Verb – Set Unsolicited Response Control (Verb ID=708h)

Enables a widget to generate an unsolicited response.

Table 52. Verb – Set Unsolicited Response Control (Verb ID=708h)

Set Command Format				Codec Response Format
Bit [31:28]	Bit [27:20]	Bit [19:8]	Payload Bit [7:0]	Response [31:0]
CAd=X	Node ID=Xh	Verb ID=708h	EnableUnsol [7:0]	0's for All Nodes

'EnableUnsol' in Command Bit[7:0] for NID=01h (GPIO in Audio Function Group), 14h~1Bh, 1Eh, 21h (Port A to I, SPDIF-OUT)

Bit	Description
31:8	Reserved. Read as 0's.
7	Enable Unsolicited Response. 0: Disable 1: Enable
6:4	Reserved. Read as 0's.
3:0	Tag for Unsolicited Response. Tag[3:0] is defined by software to assign a 4-bit tag for nodes that are enabled to generate unsolicited responses.

7.23. Verb – Get Pin Sense (Verb ID=F09h)

Returns the Presence Detect status and the impedance of a device attached to the pin.

Table 53. Verb – Get Pin Sense (Verb ID=F09h)

Get Command Format				Codec Response Format
Bit [31:28]	Bit [27:20]	Bit [19:8]	Payload Bit [7:0]	Response [31:0]
CAd=X	Node ID=Xh	Verb ID= F09h	0's	32-bit Response

Codec Response for NID = 14h~1Bh, 1Eh, 21h (Port A to I, SPDIF-OUT)

Bit	Description
31	Presence Detect Status. 0: No device is attached to the pin 1: Device is attached to the pin
30:0	Measured Impedance. The CM9881 does not support hardware impedance detection. This field is read as 0s.

Codec Response for Other NID

Bit	Description
31:0	Not Supported (Returns 00000000h).

7.24. Verb – Execute Pin Sense (Verb ID=709h)

Table 54. Verb – Execute Pin Sense (Verb ID=709h)

Command Format

Bit [31:28]	Bit [27:20]	Bit [19:8]	Payload Bit [7:0]
CAd=X	Node ID=Xh	Verb ID= 709h	Right Channel[0]

Codec Response Format

Response [31:0]
0's for All Nodes

'Payload' in Command Bit[7:0]

Bit	Description
7:1	Reserved. Read as 0's.
0	Right (Ring) Channel Select. 0: Sense Left channel (Tip) 1: Sense Right channel (Ring) The CM9881 does not support hardware impedance sensing and will ignore this control.

7.25. Verb – Get Volume Knob Widget (Verb ID=F0Fh)

Table 55. Verb – Get Volume Knob (Verb ID=F0Fh)

Get Command Format

Bit [31:28]	Bit [27:20]	Bit [19:8]	Payload Bit [7:0]
CAd=X	Node ID=21h	Verb ID= F0Fh	0's

Codec Response Format

Response [31:0]
Bit[31:8]=0s, Bit[7:0] is Volume

Codec Response for Volume Knob Widget

Bit	Description
31:8	Reserved.
7	Direct. 0: The volume generated by external HW volume control will be sent by unsolicited response. Software is responsible for programming the amplifier appropriately 1: The volume generated by external HW volume control will directly affect the volume of the amplifier.
6:0	Volume in Steps.

Note: The CM9881 does not support Volume Knob Widget and will ignore this verb and respond with 0's.

7.26. Verb – Set Volume Knob Widget (Verb ID=70Fh)

Table 56. Verb – Set Volume Knob (Verb ID=70Fh)

Set Command Format

Bit [31:28]	Bit [27:20]	Bit [19:8]	Payload Bit [7:0]
CAd=X	Node ID=21h	Verb ID= 70Fh	Bit[7] is 'Direct' Control

Codec Response Format

Response [31:0]
0's

'Payload' in Command Bit[7:0]

Bit	Description
31:8	Reserved.
7	Direct. 0: The volume generated by external HW volume control will be sent by unsolicited response. Software is responsible for programming the amplifier appropriately 1: The volume generated by external HW volume control will directly affect the volume of the amplifier.
6:0	Reserved.

Note: The CM9881 does not support Volume Knob Widget and will ignore this verb and respond with 0's.

7.27. Verb – Get Configuration Default (Verb ID=F1Ch)

Reads the 32-bit sticky register for each Pin Widget configured by software.

Table 57. Verb – Get Configuration Default (Verb ID=F1Ch)

Get Command Format				Codec Response Format
Bit [31:28]	Bit [27:20]	Bit [19:8]	Payload Bit [7:0]	Response [31:0]
CAd=X	Node ID=Xh	Verb ID= F1Ch	0's	32-bit Response

Codec Response for NID=14h~1Bh, 1Eh, 21h (Port A to I, SPDIF-OUT)

Bit	Description												
31:0	32-Bit Configuration Information for Each Pin Widget. Default value for each pin widget. [31:30]: Port Connectivity (0h: Port; 2h: Header; 1h: Not Connected) [29:24]: Location [23:20]: Default Device [19:16]: Connection Type [15:12]: Color [11:08]: Misc [07:04]: Default Association [03:00]: Sequence												
	<table border="1"> <thead> <tr> <th>NID 14h</th> <th>NID 15h</th> <th>NID 16h</th> <th>NID 17h</th> <th>NID 18h</th> <th>NID 19h</th> </tr> </thead> <tbody> <tr> <td>01011012h</td> <td>01016011h</td> <td>01012014h</td> <td>01014010h</td> <td>02A19040h</td> <td>411111F0h</td> </tr> </tbody> </table>	NID 14h	NID 15h	NID 16h	NID 17h	NID 18h	NID 19h	01011012h	01016011h	01012014h	01014010h	02A19040h	411111F0h
NID 14h	NID 15h	NID 16h	NID 17h	NID 18h	NID 19h								
01011012h	01016011h	01012014h	01014010h	02A19040h	411111F0h								
	<table border="1"> <thead> <tr> <th>NID 1Ah</th> <th>NID 1Bh</th> <th>NID 21h</th> <th>NID 1Dh</th> <th>NID 1Eh</th> </tr> </thead> <tbody> <tr> <td>01813030h</td> <td>01A1903Fh</td> <td>0221401Fh</td> <td>00000100h</td> <td>01441120h</td> </tr> </tbody> </table>	NID 1Ah	NID 1Bh	NID 21h	NID 1Dh	NID 1Eh	01813030h	01A1903Fh	0221401Fh	00000100h	01441120h		
NID 1Ah	NID 1Bh	NID 21h	NID 1Dh	NID 1Eh									
01813030h	01A1903Fh	0221401Fh	00000100h	01441120h									

Note: The 32-bit registers for each Pin Widget are sticky and will not be reset by a LINK Reset or Codec Reset (Function Reset Verb).

Table 58. Default Configuration in Chip (14h~19h)

NID=	14h	15h	16h	17h	18h	19h
Name	FRONT	SURR	CEN/LFE	HP1-OUT	MIC1	MIC2
Port	Jack	Jack	Jack	Jack	Jack	NC
Location	Rear	Rear	Rear	Rear	Front	Rear
Device	Line Out	Line Out	Line Out	Line Out	Mic In	Speaker
Con Type	1/8" Jack	1/8" Jack	1/8" Jack	1/8" Jack	1/8" Jack	1/8" Jack
Color	Black	Orange	Grey	Green	Pink	Black
Misc	*Vrefo *Retask *Sensing ✓JD	*Vrefo *Retask *Sensing ✓JD	*Vrefo *Retask *Sensing ✓JD	*Vrefo *Retask *Sensing ✓JD	✓Vrefo *Retask *Sensing ✓JD	*Vrefo *Retask *Sensing *JD
Association	1h	1h	1h	1h	4h	Fh
Sequence	2h	1h	4h	0h	0h	0h

Table 59. Default Configuration in Chip (1Ah~21h)

NID=	1Ah	1Bh	1Dh	1Eh	21h
Name	LINE1	LINE2	BEEP-IN	SPDIF-OUT	HP2-OUT
Port	Jack	Jack	Internal	Jack	Jack
Location	Rear	Rear	Unknown	Rear	Front
Device	Line In	Mic In	Other	SPDIF Out	HP Out
Con Type	1/8" Jack	1/8" Jack	Other	RCA	1/8" Jack
Color	Blue	Pink	Other	Black	Green
Misc	*Vrefo *Retask *Sensing ✓JD	✓Vrefo ✓Retask *Sensing ✓JD	*Vrefo *Retask *Sensing *JD	*Vrefo *Retask *Sensing *JD	*Vrefo *Retask *Sensing ✓JD
Association	3h	3h	0h	2h	1h
Sequence	0h	Fh	0h	0h	Fh

7.28. Verb – Set Configuration Default Bytes 0, 1, 2, 3 (Verb ID=71Ch/71Dh/71Eh/71Fh for Bytes 0, 1, 2, 3)

The BIOS can use this verb to figure out the default conditions for the Pin Widgets 14h~1Bh, 11h, 12h, 1Eh, and 1Fh, e.g., placement and expected default device.

Table 60. Verb – Set Configuration Default Bytes 0, 1, 2, 3

Set Command Format				Codec Response Format
Bit [31:28]	Bit [27:20]	Bit [19:8]	Payload Bit [7:0]	Response [31:0]
CAd=X	Node ID=Xh	Verb ID=71Ch, 71Dh, 71Eh, 71Fh	Label [7:0]	0's for All Nodes

Note: Supported by Pin Widget NID=14h~1Bh (Port-A~Port-H), 1Dh (BEEP-IN), 1Eh (SPDIF-OUT), 21h (HP2-OUT). Other widgets will ignore this verb.

Codec Response for All NID

Bit	Description
31:0	0's.

7.29. Verb – Get BEEP Generator (Verb ID=F0Ah)

Table 61. Verb – Get BEEP Generator (Verb ID= F0Ah)

Get Command Format				Codec Response Format
Bit [31:28]	Bit [27:20]	Bit [19:8]	Payload Bit [7:0]	Response [31:0]
CAd=X	Node ID=Xh	Verb ID= F0Ah	0's	Divider [7:0]

'Response' for NID=01h (Audio Function Group)

Bit	Description
31:8	Reserved.
7:0	Frequency Divider, F[7:0]. The internal BEEP frequency is the result of dividing the 48kHz clock by 4 times the number specified in F[7:0]. The lowest tone is $48\text{kHz}/(255 \times 4) = 47\text{Hz}$. The highest tone is $48\text{kHz}/(1 \times 4) = 12\text{kHz}$. A value of 00h in F[7:0] disables the internal BEEP generator and allows external PCBEEP input.

Codec Response for Other NID

Bit	Description
31:0	0's.

7.30. Verb – Set BEEP Generator (Verb ID=70Ah)

Table 62. Verb – Set BEEP Generator (Verb ID= 70Ah)

Set Command Format

Bit [31:28]	Bit [27:20]	Bit [19:8]	Payload Bit [7:0]
CAd=X	Node ID=01h	Verb ID=70Ah	Divider [7:0]

Codec Response Format

Response [31:0]
0's for All Nodes

'Divider' in Set Command

Bit	Description
31:8	Reserved.
7:0	Frequency Divider, F[7:0]. The internal BEEP frequency is the result of dividing the 48kHz clock by 4 times the number specified in F[7:0]. The lowest tone is 48kHz/(255×4)=47Hz. The highest tone is 48kHz/(1×4)=12kHz. A value of 00h in F[7:0] disables the internal BEEP generator and allows external PCBEEP input.

Note: All nodes except Audio Function Group (NID=01h) will ignore this verb.

Codec Response for All NID

Bit	Description
31:0	0's.

7.31. Verb – Get GPIO Data (Verb ID=F15h)

Table 63. Verb – Get GPIO Data (Verb ID= F15h)

Get Command Format

Bit [31:28]	Bit [27:20]	Bit [19:8]	Payload Bit [7:0]
CAd=X	Node ID=01h	Verb ID=F15h	0's

Codec Response Format

Response [31:0]
32-bit Response

Codec Response for NID=01h (Audio Function Group)

Bit	Description
31:8	Reserved.
7:1	GPIO[7:1] Data. Not supported in the CM9881.
0	GPIO[0] Data. The value written (output) or sensed (input) on the corresponding pin if it is enabled.

Codec Response for Other NID

Bit	Description
31:0	0's.

7.32. Verb – Set GPIO Data (Verb ID=715h)

Table 64. Verb – Set GPIO Data (Verb ID= 715h)

Set Command Format

Bit [31:28]	Bit [27:20]	Bit [19:8]	Payload Bit [7:0]
CAd=X	Node ID=01h	Verb ID=715h	Data [7:0]

Codec Response Format

Response [31:0]
0's for All Nodes

'Data' in Set command for NID=01h (Audio Function Group)

Bit	Description
31:8	Reserved.
7:1	GPIO[7:1] Output Data. Not supported in the CM9881.
0	GPIO[0] Output Data. The value written determines the value driven on a pin that is configured as an output pin.

Codec Response for All NID

Bit	Description
31:0	0's.

7.33. Verb – Get GPIO Enable Mask (Verb ID=F16h)

Table 65. Verb – Get GPIO Enable Mask (Verb ID= F16h)

Get Command Format

Bit [31:28]	Bit [27:20]	Bit [19:8]	Payload Bit [7:0]
CAd=X	Node ID=01h	Verb ID=F16h	0's

Codec Response Format

Response [31:0]
EnableMask [7:0]

Codec Response for NID=01h (Audio Function Group)

Bit	Description
31:1	Reserved.
0	GPIO[0] Enable Mask. 0: The corresponding GPIO pin is disabled and is in Hi-Z state 1: The corresponding GPIO pin is enabled. Its behavior is determined by the GPIO direction control

Note: All nodes except Audio Function Group (NID=01h) will ignore this verb.

Codec Response for Other NID

Bit	Description
31:0	0's.

7.34. Verb – Set GPIO Enable Mask (Verb ID=716h)

Table 66. Verb – Set GPIO Enable Mask (Verb ID=716h)

Set Command Format

Bit [31:28]	Bit [27:20]	Bit [19:8]	Payload Bit [7:0]
CAd=X	Node ID=01h	Verb ID=716h	Enable Mask [7:0]

Codec Response Format

Response [31:0]
0's for All Nodes

Codec Response for NID=01h (Audio Function Group)

Bit	Description
31:8	Reserved.
7:1	GPIO[7:1] Enable Mask. Not supported in the CM9881.
0	GPIO[0] Enable Mask. 0: The corresponding GPIO pin is disabled and is in Hi-Z state 1: The corresponding GPIO pin is enabled. Its behavior is determined by the GPIO direction control

Note: All nodes except Audio Function Group (NID=01h) will ignore this verb.

Codec Response for All NID

Bit	Description
31:0	0's.

7.35. Verb – Get GPIO Direction (Verb ID=F17h)

Table 67. Verb – Get GPIO Direction (Verb ID=F17h)

Get Command Format

Bit [31:28]	Bit [27:20]	Bit [19:8]	Payload Bit [7:0]
CAd=X	Node ID=01h	Verb ID=F17h	0's

Codec Response Format

Response [31:0]
Direction [7:0]

Codec Response for NID=01h (Audio Function Group)

Bit	Description
31:8	Reserved.
7:1	GPIO[7:1] Direction Control. Not supported in the CM9881.
0	GPIO[0] Direction Control. 0: The corresponding GPIO pin is configured as an input 1: The corresponding GPIO pin is configured as an output

Note: All nodes except Audio Function Group (NID=01h) will ignore this verb.

Codec Response for Other NID

Bit	Description
31:0	0's.

7.36. Verb – Set GPIO Direction (Verb ID=717h)

Table 68. Verb – Set GPIO Direction (Verb ID=717h)

Set Command Format				Codec Response Format
Bit [31:28]	Bit [27:20]	Bit [19:8]	Payload Bit [7:0]	Response [31:0]
CAd=X	Node ID=01h	Verb ID=717h	Direction [7:0]	0's for All Nodes

Codec Response for NID=01h (Audio Function Group)

Bit	Description
31:8	Reserved.
7:1	GPIO[7:1] Direction Control. Not supported in the CM9881.
0	GPIO[0] Direction Control. 0: The corresponding GPIO pin is configured as an input 1: The corresponding GPIO pin is configured as an output

Note: All nodes except Audio Function Group (NID=01h) will ignore this verb.

Codec Response for Other NID

Bit	Description
31:0	0's.

7.37. Verb – Get GPIO Unsolicited Response Enable Mask (Verb ID=F19h)

Table 69. Verb – Get GPIO Unsolicited Response Enable Mask (Verb ID=F19h)

Get Command Format				Codec Response Format
Bit [31:28]	Bit [27:20]	Bit [19:8]	Payload Bit [7:0]	Response [31:0]
CAd=X	Node ID=01h	Verb ID=F19h	0's	UnsolEnable [7:0]

Codec Response for NID=01h (Audio Function Group)

Bit	Description
31:8	Reserved.
7:1	GPIO[7:1] Unsolicited Enable Mask. Not supported in the CM9881.
0	GPIO[0] Unsolicited Enable Mask. 0: Unsolicited response will not be sent on link 1: Unsolicited response will be sent on link when state of corresponding GPIO has been changed

Note: All nodes except Audio Function Group (NID=01h) will ignore this verb.

Codec Response for Other NID

Bit	Description
31:0	0's.

7.38. Verb – Set GPIO Unsolicited Response Enable Mask (Verb ID=719h)

Table 70. Verb – Set GPIO Unsolicited Response Enable Mask (Verb ID=719h)

Set Command Format				Codec Response Format
Bit [31:28]	Bit [27:20]	Bit [19:8]	Payload Bit [7:0]	Response [31:0]
CAd=X	Node ID=01h	Verb ID=719h	UnsolEnable [7:0]	0's for All Nodes

Codec Response for NID=01h (Audio Function Group)

Bit	Description
31:8	Reserved.
7:1	GPIO[7:1] Unsolicited Enable Mask. Not supported in the CM9881.
0	GPIO[0] Unsolicited Enable Mask. 0: Unsolicited response will not be sent on link 1: Unsolicited response will be sent on link when state of corresponding GPIO has been changed

Note 1: All nodes except the Audio Function Group (NID=01h) will ignore this verb.

Note 2: The unsolicited response of corresponding GPIO is enabled when it's 'Enable Mask' and Verb- 'Unsolicited Response' for NID=01h are enabled.

Codec Response for Other NID

Bit	Description
31:0	0's.

7.39. Verb – Function Reset (Verb ID=7FFh)

Table 71. Verb – Function Reset (Verb ID=7FFh)

Command Format (NID=01h)				Codec Response Format
Bit [31:28]	Bit [27:20]	Bit [19:8]	Payload Bit [7:0]	Response [31:0]
CAd=X	Node ID=01h	Verb ID=7FFh	0's	0's

Codec Response

Bit	Description
31:0	Reserved. Read as 0's.

Note: The Function Reset command causes all widgets in the CM9881 to return to their power on default state.

7.40. Verb – Get Digital Converter Control 1, 2, 3, 4 (Verb ID=F0Dh, F0Eh, F3Eh, F3Fh)

Table 72. Verb – Get Digital Converter Control 1, 2, 3, 4 (Verb ID=F0Dh, F0Eh, F3Eh, F3Fh)

Get Command Format

Bit [31:28]	Bit [27:20]	Bit [19:8]	Payload Bit [7:0]
CAd=X	Node ID=Xh	Verb ID=F0Dh/F0Eh/ F3Eh/F3Fh	0's

Codec Response Format

Response [31:0]
Bit[31:16]=0's, Bit[15:0] are SIC Bit

NID=06h (SPDIF-OUT) Response to 'Get verb' – F0Dh/F0Eh/F3Eh/F3Fh

Bit	Description – SIC (SPDIF IEC Control) Bit[15:0]
31:24	Read as 0's.
23	Keep Alive Enable. 0: Disable (SPDIF output is disabled in D2/D3 mode) 1: Enable (SPDIF output is enabled in D2/D3 mode)
22:20	Reserved. Read as 0's.
19:16	IEC Coding Type. Not supported in CM9881, read as 0's.
15	Reserved. Read as 0's.
14:8	CC[6:0] (Category Code).
7	LEVEL (Generation Level).
6	PRO (Professional or Consumer Format). 0: Consumer format 1: Professional format
5	/AUDIO (Non-Audio Data Type). 0: PCM data 1: AC3 or other digital non-audio data
4	COPY (Copyright). 0: Asserted 1: Not asserted
3	PRE (Pre-Emphasis). 0: None 1: Filter pre-emphasis is 50/15 microseconds
2	VCFG for Validity Control (Control V Bit and Data in Sub-Frame).
1	V for Validity Control (Control V Bit and Data in Sub-Frame).
0	Digital Enable (DigEn). 0: OFF 1: ON

Codec Response for Other NID

Bit	Description
31:0	0's.

7.41. Verb – Set Digital Converter Control 1, 2, 3, 4 (Verb ID=70Dh, 70Eh, 73Eh, 73Fh)

Table 73. Verb – Set Digital Converter Control 1, 2, 3, 4 (Verb ID=70Dh, 70Eh, 73Eh, 73Fh)

Set Command Format (Verb ID=70Dh, Set Control 1)

Bit [31:28]	Bit [27:20]	Bit [19:8]	Payload Bit [7:0]
CAd=X	Node ID=Xh	Verb ID=70Dh	SIC [7:0]

Codec Response Format

Response [31:0]
0's

Set Command Format (Verb ID=70Eh, Set Control 2)

Bit [31:28]	Bit [27:20]	Bit [19:8]	Payload Bit [7:0]
CAd=X	Node ID=Xh	Verb ID=70Eh	SIC [15:8]

Codec Response Format

Response [31:0]
0's

Set Command Format (Verb ID=73Eh, Set Control 3)

Bit [31:28]	Bit [27:20]	Bit [19:8]	Payload Bit [7:0]
CAd=X	Node ID=Xh	Verb ID=73Eh	SIC [23:16]

Codec Response Format

Response [31:0]
0's

Set Command Format (Verb ID=73Fh, Set Control 4)

Bit [31:28]	Bit [27:20]	Bit [19:8]	Payload Bit [7:0]
CAd=X	Node ID=Xh	Verb ID=73Fh	SIC [31:24]

Codec Response Format

Response [31:0]
0's

'Payload' in Set Control 1 for NID=06h (SPDIF-OUT)

Bit	Description – SIC (SPDIF IEC Control) Bit[7:0]
7	LEVEL (Generation Level).
6	PRO (Professional or Consumer Format). 0: Consumer format 1: Professional format
5	/AUDIO (Non-Audio Data Type). 0: PCM data 1: AC3 or other digital non-audio data
4	COPY (Copyright). 0: Asserted 1: Not asserted
3	PRE (Pre-Emphasis). 0: None 1: Filter pre-emphasis is 50/15 microseconds
2	VCFG for Validity Control (Control V Bit and Data in Sub-Frame).
1	V for Validity Control (Control V Bit and Data in Sub-Frame).
0	Digital Enable (DigEn). 0: OFF 1: ON

'Payload' in Set Control 2 for NID=06h (SPDIF-OUT)

Bit	Description – SIC (SPDIF IEC Control) Bit[7:0]
7	Reserved. Read as 0's.
6:0	CC[6:0] (Category Code).

'Payload' in Set Control 3 for NID=06h (SPDIF-OUT)

Bit	Description – SIC (SPDIF IEC Control) Bit[23:16]
7	Keep Alive Enable. 0: Disable (SPDIF output is disabled in D2/D3 mode) 1: Enable (SPDIF output is enabled in D2/D3 mode)
6:0	Reserved.

'Payload' in Set Control 4 for NID=06h (SPDIF-OUT)

Bit	Description – SIC (SPDIF IEC Control) Bit[31:24]
7:0	Reserved.

Note: Other widgets will ignore this verb.

7.42. Verb – Get Subsystem ID [31:0] (Verb ID=F20h/F21h/F22h/F23h)

32-bit Read/Write register for Audio Function Group (NID=01h)

Table 74. Verb – Get Subsystem ID [31:0] (Verb ID=F20h/F21h/F22h/F23h)

Get Command Format

Bit [31:28]	Bit [27:20]	Bit [19:8]	Payload Bit [7:0]
CAd = X	Node ID=01h	Verb ID=F20h	0s

Codec Response Format

Response [31:0]
32-bit Response

Codec Response for NID=01h

Bit	Description
31:16	Subsystem ID[23:8] (Default=10ECh).
15:8	Subsystem ID[7:0] (Default=08h).
7:0	Assembly ID[7:0] (Default=67h).

7.43. Verb – Set Subsystem ID [31:0] (Verb ID=723h for [31:24], 722h for [23:16], 721h for [15:8], 720h for [7:0])

Table 75. Verb – Set Subsystem ID [31:0]
(Verb ID=723h for [31:24], 722h for [23:16], 721h for [15:8], 720h for [7:0])

Set Command Format

Bit [31:28]	Bit [27:20]	Bit [19:8]	Payload Bit [7:0]
CAd = X	Node ID=01h	Verb ID=723h, 722h, 721h, 720h	Label [7:0]

Codec Response Format

Response [31:0]
0s for All Nodes

Codec Response for all NID

Bit	Description
31:0	0s.

7.44. Verb – Get EAPD Control (Verb ID=F0Ch for Get)

Table 76. Verb – Get EAPD Control (Verb ID=F0Ch)

Get Command Format (NID=14h and 15h)

Bit [31:28]	Bit [27:20]	Bit [19:8]	Payload Bit [7:0]
CAd=X	Node ID=14h/1Bh	Verb ID=F0Ch	0s

Codec Response Format

Response [31:0]
Bit[1] is EAPD Control

Codec Response for NID=14h (FRONT, port-D) and 1Bh (LINE2, port-E)

Bit	Description
31:3	Reserved.
2	L-R Swap. The CM9881 does not support swapping left and right channels. Read as 0.
1	EAPD Value. 0: EAPD pin state is low 1: EAPD pin state is high
0	Bridge Tied Load (BTL) Enable. The CM9881 does not support BTL output. Read as 0.

Codec Response in for Other NID

Bit	Description
31:0	0's.

7.45. Verb – Set EAPD Control (Verb ID=70Ch for Set)

Table 77. Verb – Set EAPD Control (Verb ID=70Ch for Set)

Set Command Format (NID=14h and 15h)

Codec Response Format

Bit [31:28]	Bit [27:20]	Bit [19:8]	Payload Bit [7:0]
CAd=X	Node ID=14h/1Bh	Verb ID=70Ch	Bit[1] is EAPD Control

Response [31:0]
0s

Payload in Set Command for 17h (HP1-OUT, port-H) and 21h (HP2-OUT, port-I)

Bit	Description
7:3	Reserved. Written Data is Ignored.
2	L-R Swap. The CM9881 does not support swapping left and right channels, written data is ignored.
1	EAPD Value. 0: EAPD pin state is low 1: EAPD pin state is high
0	Bridge Tied Load (BTL) Enable. The CM9881 does not support BTL output. Written data is ignored.

Note: Pin 47 is shared by the EPAD and SPDIF-IN functions. Pin 47 will act as EAPD and reflect the set EAPD state in payload bit[1] when pin widget SPDIF-IN is not connected via the programming configuration register. Other widgets will ignore this verb.

Codec Response

Bit	Description
31:0	0's.

8. Electrical Characteristics

8.1. DC Characteristics

8.1.1. Absolute Maximum Ratings

Table 78. Absolute Maximum Ratings

Parameter	Symbol	Minimum	Typical	Maximum	Units
Power Supply					
Digital Power for Core	DVDD/HPVDD	3.0	3.3	3.6	V
Digital Power for HDA Link	DVDD-IO*	1.5	3.3	3.6	V
Analog	AVDD**	4.5	5.0	5.5	V
	ALDO-CAP	4.05	4.5	4.95	V
Ambient Operating Temperature	Ta	0	-	+70	°C
Storage Temperature	Ts	-	-	+125	°C
ESD (Electrostatic Discharge)					
		Susceptibility Voltage			
All Pins		3500			

*: The digital link power DVDD-IO must be equal or lower than the digital power DVDD.

** : The standard testing condition before shipping is AVDD = 5.0V unless specified.

8.1.2. Threshold Voltage

DVDD-IO= 1.5V±5%/3.3V±5%, DVDD= 3.3V±5%, T_{ambient}=25°C, with 50pF external load.

Table 79. Threshold Voltage

Parameter	Symbol	Minimum	Typical	Maximum	Units
Input Voltage Range	V _{in}	-0.30	-	DVDD+0.30	V
Low Level Input Voltage (HDA link)	V _{IL}	-	-	0.4×DVDD-IO	V
High Level Input Voltage (HDA link)	V _{IH}	0.6×DVDD-IO	-	-	V
High Level Output Voltage (HDA link)	V _{OH}	0.9×DVDD-IO	-	-	V
Low Level Output Voltage (HDA link)	V _{OL}	-	-	0.1×DVDD-IO	V
Low Level Input Voltage (GPIOs)	V _{IL}	-	-	0.44×DVDD (1.45)	V
High Level Input Voltage (GPIOs)	V _{IH}	0.56×DVDD (1.85)	-	-	V
High Level Output Voltage (SPDIF-OUT, GPIOs)	V _{OH}	0.9×DVDD	-	-	V
Low Level Output Voltage (SPDIF-OUT, GPIOs)	V _{OL}	-	-	0.1×DVDD	V
Input Leakage Current	-	-10	-	10	μA
Output Leakage Current (Hi-Z)	-	-10	-	10	μA
Output Buffer Drive Current	-	-	5	-	mA
Internal Pull Up Resistance	-	-	50k	-	Ω

8.1.3. Digital Filter Characteristics

Table 80. Digital Filter Characteristics

Filter	Description	Minimum	Typical	Maximum	Units
ADC Filter	Passband (Upper Band < -0.030dB)	-	0.4350×Fs	-	KHz
	Passband (Upper Band < -1.0dB)	-	0.4571×Fs	-	KHz
	Passband Ripple	-	-	±0.030	dB
	Stopband	0.565×Fs	-	-	KHz
	Stopband Attenuation	80	-	-	dB
ADC Highpass Filter	Passband Frequency Response: -0.15dB (Fs=192000)	-	20	-	Hz
DAC Lowpass Filter	Passband Frequency Response: -0.03dB	-	0.441×Fs	-	KHz
	Stopband	0.559×Fs	-	1.5×Fs	KHz
	Stopband Rejection	90	-	-	dB
	Passband Ripple	-	-	±0.030	dB
DAC Highpass Filter	Passband Frequency Response: -0.15dB (Fs=192000)	-	20	-	Hz

Note: Fs=Sample rate.

8.1.4. SPDIF Output Characteristics

DVDD=3.3V, T_{ambient}=25°C, with 75Ω external load.

Table 81. SPDIF Output Characteristics

Parameter	Symbol	Minimum	Typical	Maximum	Units
SPDIF-OUT High Level Output	V _{OH}	3.0	3.3	-	V
SPDIF-OUT Low Level Output	V _{OL}	-	0	0.3	V

8.2. AC Characteristics

8.2.1. Link Reset and Initialization Timing

Table 82. Link Reset and Initialization Timing

Parameter	Symbol	Minimum	Typical	Maximum	Units
RESET# Active Low Pulse Width	T_{RST}	100.167	-	-	μs
RESET# Inactive to BCLK Startup Delay for PLL Ready Time	T_{PLL}	100	-	-	μs
SDI Initialization Request	T_{FRAME}	-	-	25	Frame Time

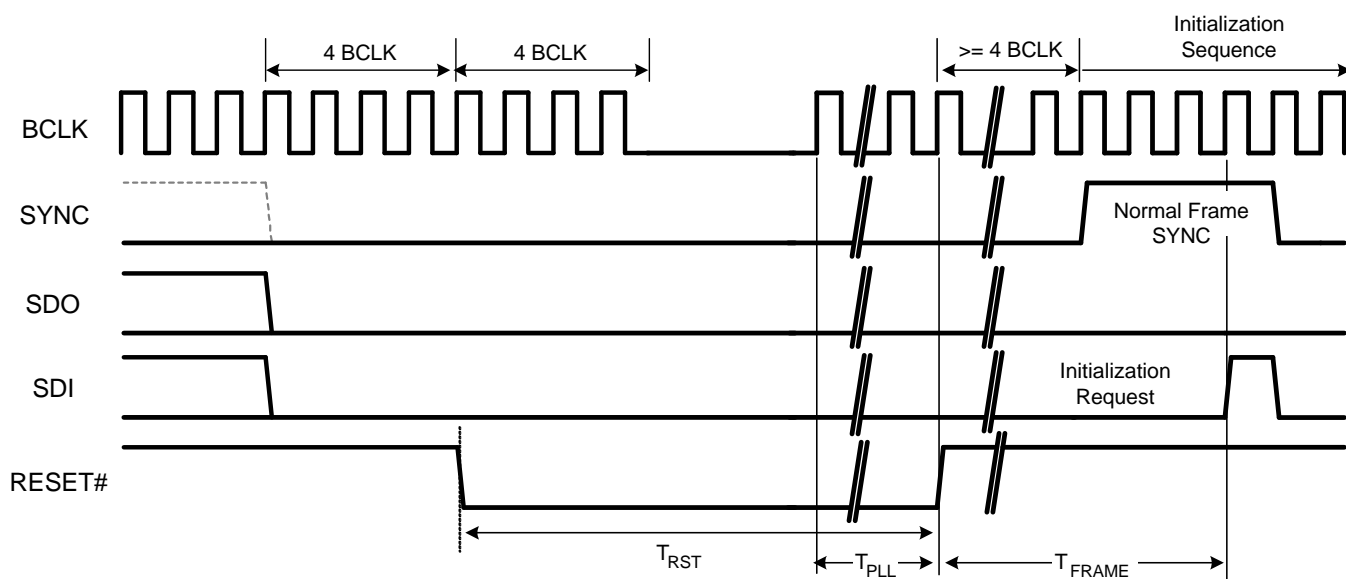
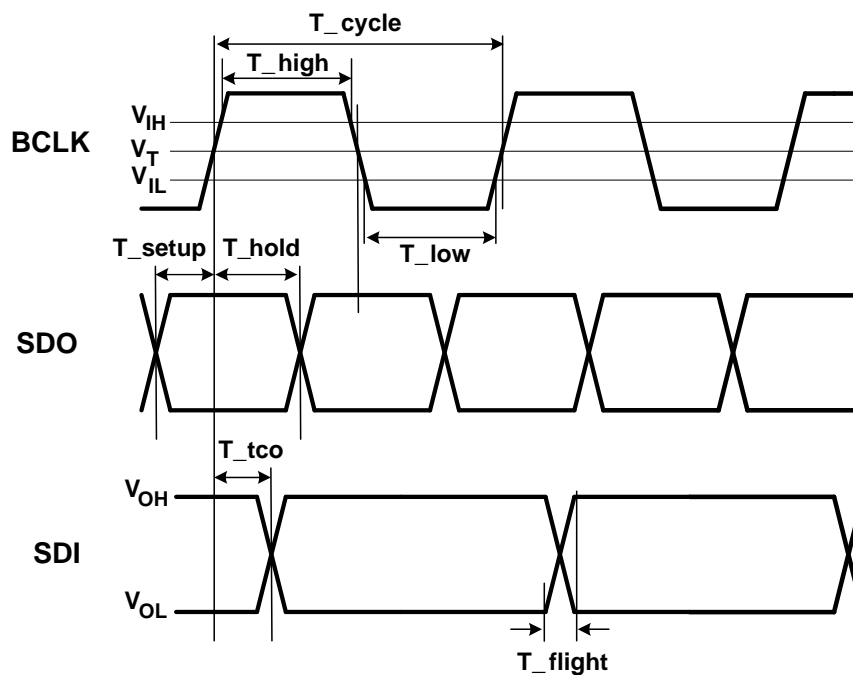

Figure 16. Link Reset and Initialization Timing

8.2.2. Link Timing Parameters at the Codec

Table 83. Link Timing Parameters at the Codec

Parameter	Symbol	Minimum	Typical	Maximum	Units
BCLK Frequency	-	23.9976	24.0	24.0024	MHz
BCLK Period	T_{cycle}	41.163	41.67	42.171	ns
BCLK Jitter	T_{jitter}	-	150	500	ps
BCLK High Pulse Width	T_{high}	17.5	-	24.16	ns
BCLK Low Pulse Width	T_{low}	17.5	-	24.16	ns
SDO Setup Time at Both Rising and Falling Edge of BCLK	T_{setup}	5	-	-	ns
SDO Hold Time at Both Rising and Falling Edge of BCLK	T_{hold}	5	-	-	ns
SDI Valid Time After Rising Edge of BCLK (1:50pF External Load)	T_{tco}	3	-	11.0	ns
SDI Flight Time	T_{flight}	0	-	7	ns

Figure 17. Link Signals Timing

8.2.3. SPDIF Output and Input Timing

Table 84. SPDIF Output and Input Timing

Parameter	Symbol	Minimum	Typical	Maximum	Units
SPDIF-OUT Frequency	-	-	3.072	-	MHz
SPDIF-OUT Period ¹	T_{cycle}	-	325.6	-	ns
SPDIF-OUT Jitter	T_{jitter}	-	-	4	ns
SPDIF-OUT High Level Width	T_{High}	156.2 (48%)	162.8 (50%)	169.2 (52%)	ns (%)
SPDIF-OUT Low Level Width	T_{Low}	156.2 (48%)	162.8 (50%)	169.2 (52%)	ns (%)
SPDIF-OUT Rising Time	T_{rise}	-	2.0	-	ns
SPDIF-OUT Falling Time	T_{fall}	-	2.0	-	ns
SPDIF-IN Period ²	T_{cycle}	-	325.6	-	ns
SPDIF-IN Jitter	T_{jitter}	-	-	10	ns
SPDIF-IN High Level Width	T_{High}	146.4 (45%)	162.8 (50%)	179 (55%)	ns (%)
SPDIF-IN Low Level Width	T_{Low}	146.4 (45%)	162.8 (50%)	179 (55%)	ns (%)

Note 1: Bit parameters for 48kHz sample rate of SPDIF-OUT.

Note 2: Bit parameters for 48kHz sample rate of SPDIF-IN.

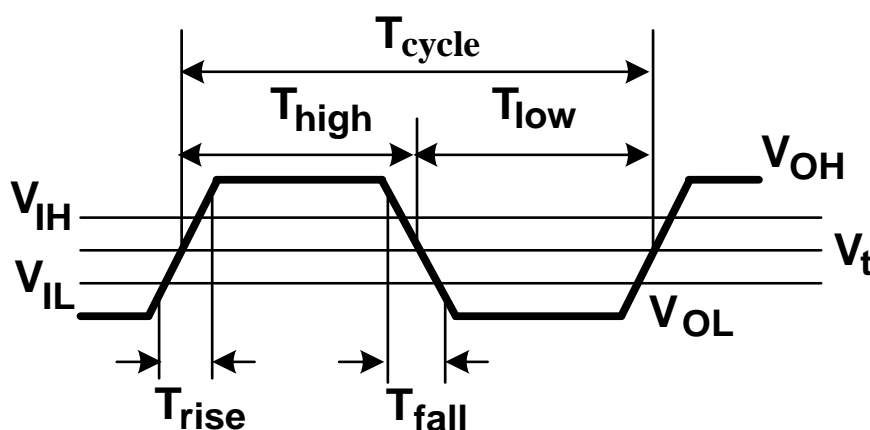
Figure 18. Output and Input Timing

8.2.4. Test Mode

The CM9881 does not support test mode or Automatic Test Equipment (ATE) mode.

8.3. Analog Performance

- Standard Test Conditions
- $T_{\text{ambient}}=25^{\circ}\text{C}$, DVDD=3.3V±5%, AVDD=5.0V±5%
 - 1kHz input sine wave; Sampling frequency=48kHz; 0dB=1Vrms
 - 10KΩ/50pF load; Test bench Characterization BW:10Hz~22kHz

Table 85. Analog Performance

Parameter	Min	Typical	Max	Units
Full-Scale Input Voltage All Inputs (Gain=0dB) to ADC	-	1.5	-	Vrms
Full-Scale Output Voltage (Gain=0dB)				
DAC	-	1.15	-	Vrms
Headphone Amplifier Output @32Ω Load	-	1.05	-	Vrms
Dynamic Range with -60dB Signal (A-Weight)				
ADC	-	92	-	dB FSA
DAC	-	97	-	dB FSA
Headphone Amplifier Output @32Ω Load	-	94	-	dB FSA
THD+N with -3dB Signal (No A-Weight)				
ADC from Port-C and Port-F	-	-85	-	dB FS
ADC from Other Port Except Port-C and Port-F	-	-85	-	dB FS
DAC to All Port	-	-85	-	dB FS
Headphone Amplifier Output @32Ω Load	-	-75	-	dB FS
Magnitude Response (10KΩ Load)				
All DAC @Fs=48KHz (FR=±0.05dB)	0	-	21,792	Hz
All DAC @Fs=96KHz (FR=±0.05dB)	0	-	43,584	Hz
All DAC @Fs=192KHz (FR=±0.05dB)	0	-	87,168	Hz
All ADC @Fs=48KHz (FR=±0.04dB)	0	-	19,200	Hz
All ADC @Fs=96KHz (FR=±0.04dB)	0	-	38,400	Hz
All ADC @Fs=192KHz (FR=±0.04dB)	0	-	76,800	Hz
Power Supply Rejection (Measured at 1kHz Point)	-	-72	-	dB
Amplifier Gain Step	-	1.0	-	dB
Channel Separation (Crosstalk)	-	-80	-	dB
Input Impedance (Gain=0dB)	-	64	-	KΩ
Output Impedance				
Amplified Output	-	2	-	Ω
Non-Amplified Output	-	200	-	Ω
Power consumption @ D3Hot, HD-A Link Alive	-	15.6	-	mW
Power consumption @ D3Hot, HD-A Link Stops	-	14	-	mW
Standby Current @ Standby mode (only AVDD=5.0V)	-	505	-	μA
VREFOUTx Output Voltage	-	0.5×ALDO-CAP	0.8×LOD-OUT1	V
VREFOUTx Output Current	-	5	-	mA

9. Application Supplements

9.1. Standby Mode

In standby mode the CM9881 turns on DC bias on all analog input and output ports (NID=14h~1Bh). This is a special application to avoid ‘Pop’ noise while the system is in power on and power off transition stages.

Table 86 shows the DC bias state when Standby mode is enabled.

Table 86. Standby Mode

+3.3V on DVDD (Pin-1)	+5VA on AVDD	Operation Mode
No (<2.0V)	No	Shut Down
No (<2.0V)	Yes	Standby Mode
Yes (>2.0V)	No	Normal
Yes (>2.0V)	Yes	Normal

10. Mechanical Dimensions

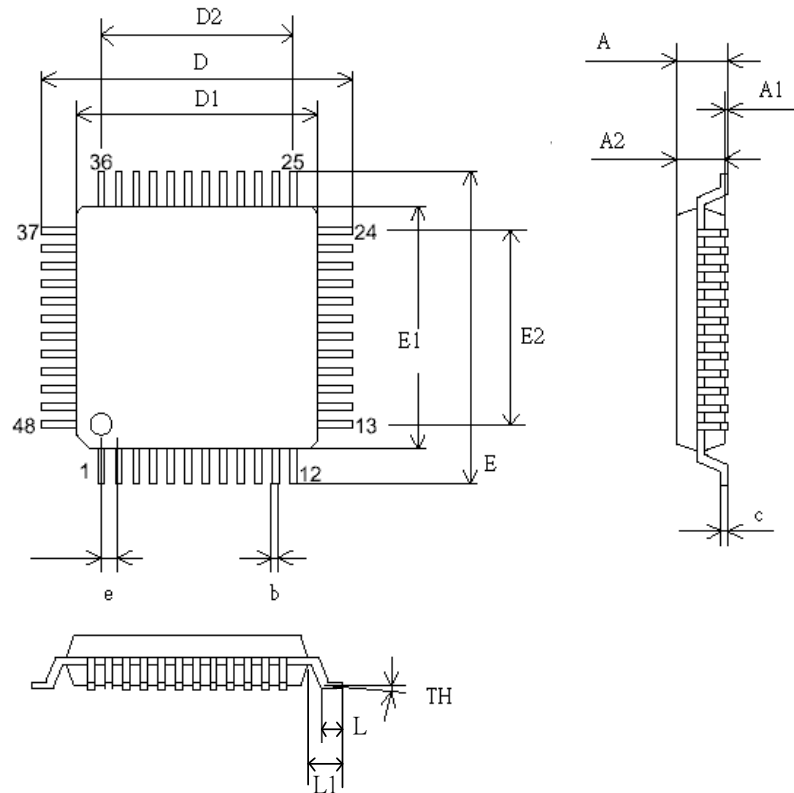

SYMBOL	MILLIMETER			INCH		
	MIN	TYP	MAX	MIN	TYP	MAX
A	-	-	1.60	-	-	0.063
A1	0.05	-	0.15	0.002	-	0.006
A2	1.35	1.40	1.45	0.053	0.055	0.057
c	0.09	-	0.20	0.004	-	0.008
D	9.00 BSC			0.354 BSC		
D1	7.00 BSC			0.276 BSC		
D2	5.50			0.217		
E	9.00 BSC			0.354 BSC		
E1	7.00BSC			0.276 BSC		
E2	5.50			0.217		
b	0.17	0.20	0.27	0.007	0.008	0.011
e	0.50 BSC			0.0196 BSC		
TH	0°	3.5°	7°	0°	3.5°	7°
L	0.45	0.60	0.75	0.018	0.0236	0.030
L1	-	1.00	-	-	0.0393	-

TITLE: LQFP-48 (7.0x7.0x1.6mm)
PACKAGE OUTLINE DRAWING,
FOOTPRINT 2.0mm

11. Ordering Information

Table 87. Ordering Information

Part Number	Description	Status
CM9881-CG	LQFP-48 with 'Green' Package	MP