

High Performance, Constant Current Switching Regulator For 11PCS White LED In Series

General Description

The LP3321 is a 1.0MHz PWM boost switching regulator designed for constant-current white LED driver applications. The LP3321 can drive a string of up to 11 white LEDs in series, ensuring uniform brightness and eliminating several ballast resistors. The LP3321 implements a constant frequency 1.0MHz PWM control scheme. The high frequency PWM operation also saves board space by reducing external component sizes. To improve efficiency, the feedback voltage is set to 200mV, which reduces the power dissipation in the current setting resistor.

Highly integration and internal compensation network minimizes as 5 external component counts. Optimized operation frequency can meet the requirement of small LC filters value and low operation current with high efficiency.

Order Information

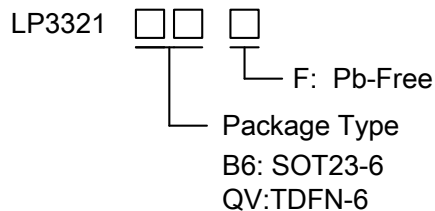

Applications

- ✧ WLED Backlight driver
- ✧ OLED Backlight driver
- ✧ PDA
- ✧ MID/PTV

Features

- ◆ Up to 94% efficiency
- ◆ Shut-down current:<1uA
- ◆ Output voltage Up to 37V
- ◆ Internal Compensation, Soft-start
- ◆ Support down to 1% Dimming Duty Cycle
- ◆ 1.0MHz fixed frequency switching
- ◆ High switch on current:1.5A
- ◆ Available in SOT23-6&TDFN-6(2mm×2mm) Package

Typical Application Circuit

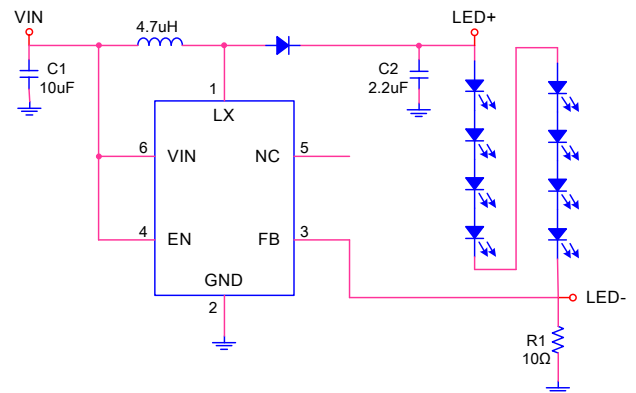

Marking Information

Device	Marking	Package	Shipping
LP3321B6F	LPS FtYWx	SOT23-6	3K/REEL
LP3321QVF	LPS FtYWx	TDFN-6	4K/REEL

Marking indication:
Y:Production year W:Production week X:Production batch



Functional Pin Description

Package Type	Pin Configurations
SOT23-6	<p>SOT23-6 TOP VIEW</p>
TDFN-6	<p>TDFN-6 TOP VIEW</p>

Pin Description

Pin		Name	Description
SOT23-6	TDFN-6		
1	4	LX	Output Switching Node.
2	3	GND	Ground Pin
3	1	FB	Feedback Reference Voltage Pin. Series connect a resistor between WLED and ground as a current sense. Sense the current feedback voltage to set the current rating.
4	5	EN	Chip Enable (Active High). Voltage sensing input to trigger the function of over voltage protection. Note that this pin is high impedance. There should be a pull low 100kΩ resistor connected to GND when the control signal is floating.
5	2	NC	No Connect
6	6	VIN	Supply Input Voltage Pin. Bypass 1uF capacitor to GND to reduce the input noise.



Function Block Diagram

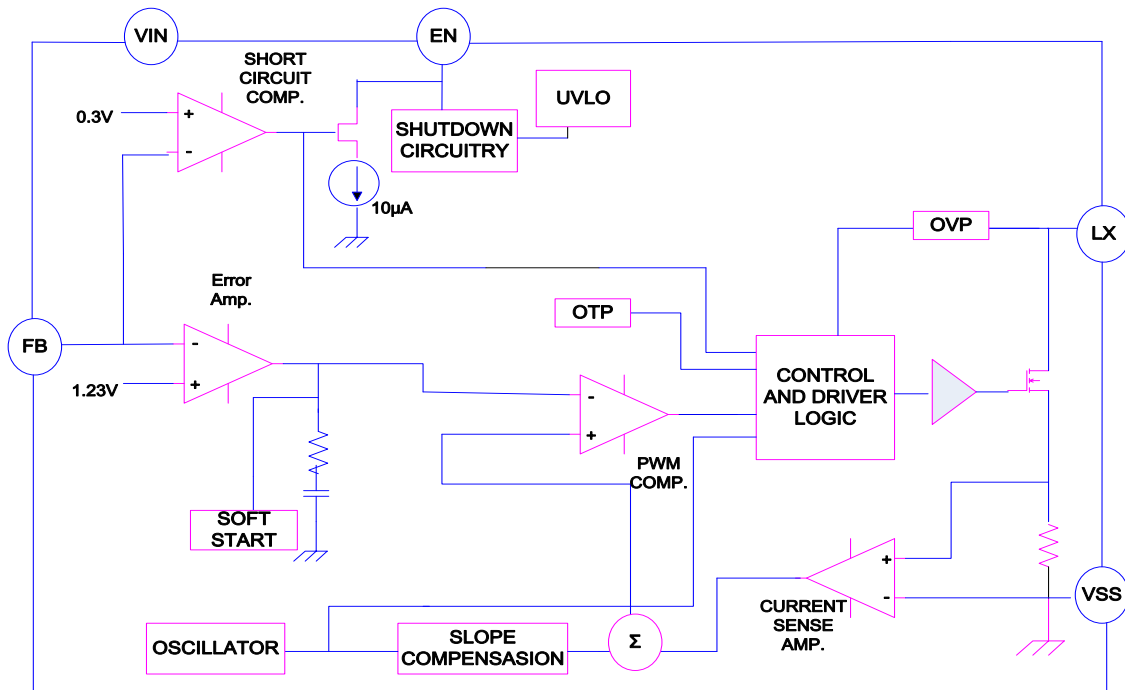

Absolute Maximum Ratings ^{Note 1}

- ✧ Input Voltage to GND ----- -0.3V to 6.5V
- ✧ LX /FB to GND ----- -0.3V to 46V
- ✧ Other pin to GND ----- -0.3V to 6.5V
- ✧ Operating Junction Temperature Range (T_J) ----- -40°C to 85°C
- ✧ Storage Temperature Range ----- -65°C to 165°C
- ✧ Maximum Soldering Temperature (at leads, 10 sec) ----- 260°C

Note 1. Stresses beyond those listed under “Absolute Maximum Ratings” may cause permanent damage to the device. These are stress ratings only, and functional operation of the device at these or any other conditions beyond those indicated in the operational sections of the specifications is not implied. Exposure to absolute maximum rating conditions for extended periods may affect device reliability.

Thermal Information

- ✧ Maximum Power Dissipation (P_D,T_A=25°C) ----- 0.5W
- ✧ Thermal Resistance ----- 250°C/W
- ✧ Maximum Power Dissipation (TDFN-6, P_D,T_A=25°C) ----- 1.2W
- ✧ Thermal Resistance (TDFN-6, J_A) ----- 95°C/W

ESD Susceptibility

- ✧ HBM(Human Body Mode) ----- 2KV
- ✧ MM(Machine Mode) ----- 200V



Electrical Characteristics

($V_{IN}=3.3V$, $C_{IN}=10\mu F$, $C_{OUT}=2.2\mu F$, $L=4.7\mu H$)

Parameter	Conditions	Min	Typ	Max	Units
Supply Voltage		2.5		5.5	V
Input Under Voltage Lock Out	UVLO		2.3		V
UVLO Hysteresis Voltage			0.25		V
Over voltage threshold			37		V
Supply Current(Shutdown)	$V_{EN}= 0V$		0.05	1	μA
Supply Current	$V_{EN}=HIGH, V_{FB}> 0.2V$		300		μA
	$V_{EN}=HIGH, V_{FB}<0.2V$		1		mA
Feedback Voltage		190	200	210	mV
Feedback Input Current			50		nA
Switching Frequency			1		MHz
Maximum Duty Cycle			90		%
EN Input Low Voltage				0.4	V
EN Input High Voltage		1.4			V
PWM EN demming range		200		200K	Hz
Duty cycle range	PWM<50KHz	1		100	%
MOSFET On Resistance			400		m Ω
MOSFET Current			1.5		A
OTP			160		$^{\circ}C$
OTP Hysteresis			20		$^{\circ}C$



Operation Information

LED Current Control

The LP3321 regulates the LED current by setting the current sense resistor (R1) connecting to feedback and ground. The internal feedback reference voltage is 200mV. The LED current can be set from following equation easily.

$$I_{LED} = 200mV / R1$$

In order to have an accurate LED current, precision resistors are preferred (1% is recommended). The table for R1 selection is shown below.

Power Sequence

In order to assure the normal soft start function for suppressing the inrush current the input voltage should be ready before EN pulls high.

Soft-Start

The function of soft-start is made for suppressing the inrush current to an acceptable value at the beginning of power-on. The LP3321 provides a built-in soft-start function by clamping the output voltage of error amplifier so that the duty cycle of the PWM will be increased gradually in the soft-start period.

Current Limiting

The current flow through inductor as charging period is detected by a current sensing circuit. As the value comes across the current limiting threshold, the N-MOSFET will be turned off so that the inductor will be forced to leave charging stage and enter discharging stage. Therefore, the inductor current will not increase over the current limiting threshold.

OVP/UVLO/OTP

The Over Voltage Protection is detected by a junction breakdown detecting circuit. Once V_{OUT} goes over the detecting voltage, LX pin stops switching and the power N-MOSFET will be turned off. As the output voltage is higher than a specified value or input voltage is lower than a specified value, the chip will enter protection mode to prevent abnormal function. As the die temperature is higher than 160°C, the chip also will enter protection mode. The power MOSFET will be turned off during protection mode to prevent abnormal operation.

Inductor Selection

The recommended value of inductor for 2 to 11 WLEDs applications are 2.2 to 10μH. Small size and better efficiency are the major concerns for portable device, such as LP3321 used for mobile phone. The inductor should have low core loss at 1.0MHz and low DCR for better efficiency. To avoid inductor saturation current rating should be considered.

Capacitor Selection

Input ceramic capacitor of 2.2μF and output ceramic capacitor of 1μF are recommended for the LP3321 applications for driving 11 series WLEDs.

For better voltage filtering, ceramic capacitors with low ESR are recommended. X5R and X7R types are suitable because of their wider voltage and temperature ranges.



Dimming control

a. Using a PWM Signal to EN Pin

For controlling the LED brightness, the LP3321 can perform the dimming control by applying a PWM signal to EN pin. The internal soft-start and wide range dimming frequency from 100Hz to 100KHz can insignificantly reduce audio noise when dimming. The average LED current is proportional to the PWM signal duty cycle. The magnitude of the PWM signal should be higher than the maximum enable voltage of EN pin, in order to let the dimming control perform correctly.

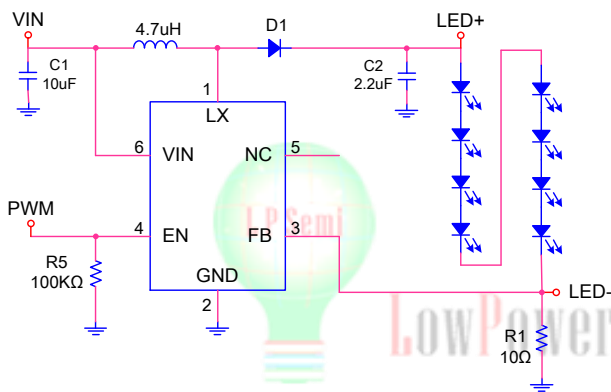

b. Using a DC Voltage

Using a variable DC voltage to adjust the brightness is a popular method in some applications. The dimming control using a DC voltage circuit is shown in below. According to the Superposition Theorem, as the DC voltage increases, the voltage contributed to VFB increases and the voltage drop on R2 decreases, i.e. the LED current decreases. For example, if the VDC range is from 0V to 2.8V, the selection of resistors in below sets dimming control of LED current from 20mA to 0mA.

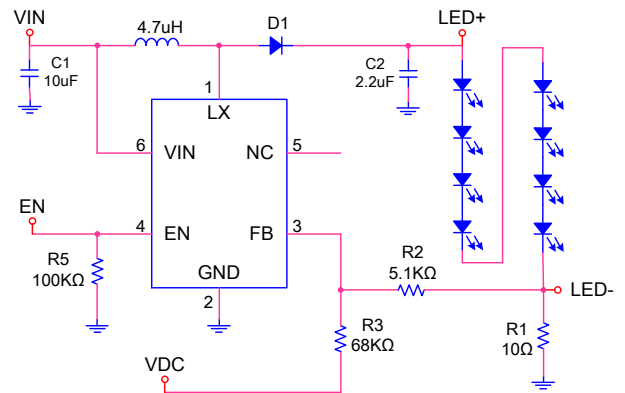

c. Using a Filtered PWM signal

Another common application is using a filtered PWM signal as an adjustable DC voltage for LED dimming control. A filtered PWM signal acts as the DC voltage to regulate the output current. The suggested application circuit is shown in the below. In this circuit, the output ripple depends on the frequency of PWM signal. For smaller output voltage ripple (<100mV), the recommended frequency of 2.8V PWM signal should be above 2KHz. To fix the frequency of PWM signal and change the duty cycle of PWM signal can get different output current. According to the application circuit of below, output current is from 30mA to 10mA by adjusting the PWM duty cycle from 10% to 90%.

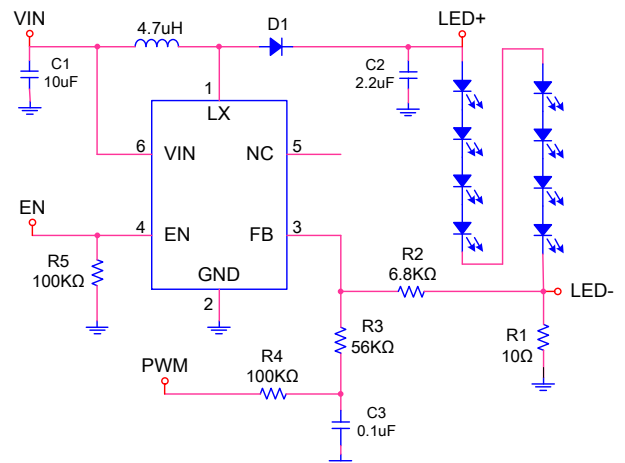



Layout Consideration

For best performance of the LP3321, the following guidelines must be strictly followed.

- ※ Input and Output capacitors should be placed close to the IC and connected to ground plane to reduce noise coupling.
- ※ The GND and Exposed Pad should be connected to a strong ground plane for heat sinking and noise protection.
- ※ Keep the main current traces as possible as short and wide.
- ※ LX node of DC-DC converter is with high frequency voltage swing. It should be kept at a small area.
- ※ Place the feedback components as close as possible to the IC and keep away from the noisy devices.

Thermal Considerations

For continuous operation, do not exceed absolute maximum operation junction temperature. The maximum power dissipation depends on the thermal resistance of IC package, PCB layout, the rate of surroundings airflow and temperature difference between junction to ambient.

The maximum power dissipation can be calculated by following formula:

$$P_{D(MAX)} = (T_{J(MAX)} - T_A) / q_{JA}$$

Where $T_{J(MAX)}$ is the maximum operation junction temperature. T_A is the ambient temperature and the q_{JA} is the junction to ambient thermal resistance.





Package Information

TDFN-6

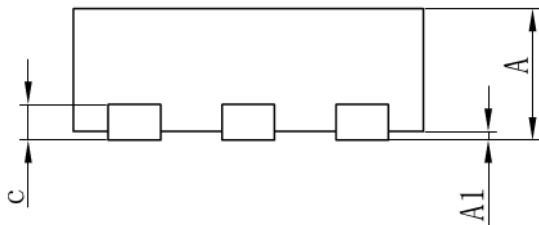
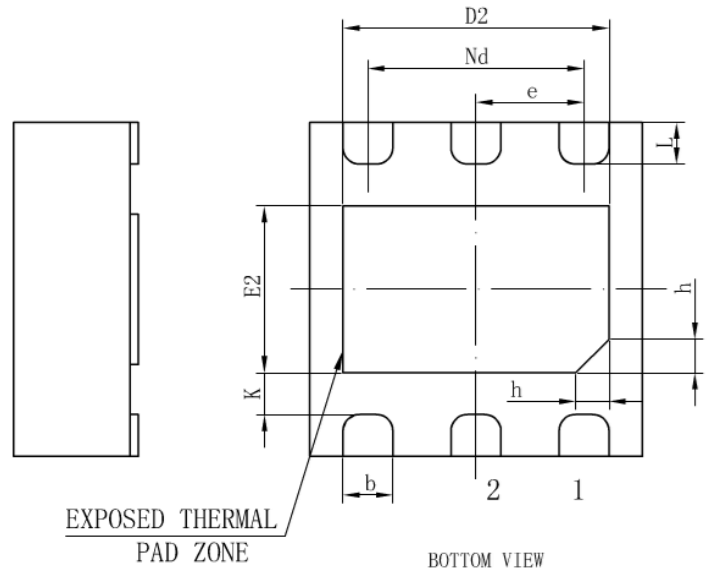
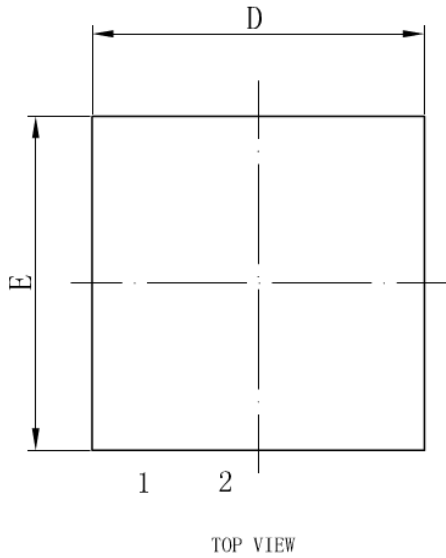

SYMBOL	MILLIMETER		
	MIN	NOM	MAX
A	0.70	0.75	0.80
A1	0	0.02	0.05
b	0.25	0.30	0.35
c	0.18	0.20	0.25
D	1.90	2.00	2.10
D2	1.50	1.60	1.70
e	0.65BSC		
Nd	1.30BSC		
E	1.90	2.00	2.10
E2	0.90	1.00	1.10
K	0.20	-	-
L	0.20	0.25	0.30
h	0.15	0.20	0.25
L/F载体尺寸 (MIL)	69X47		



SOT23-6

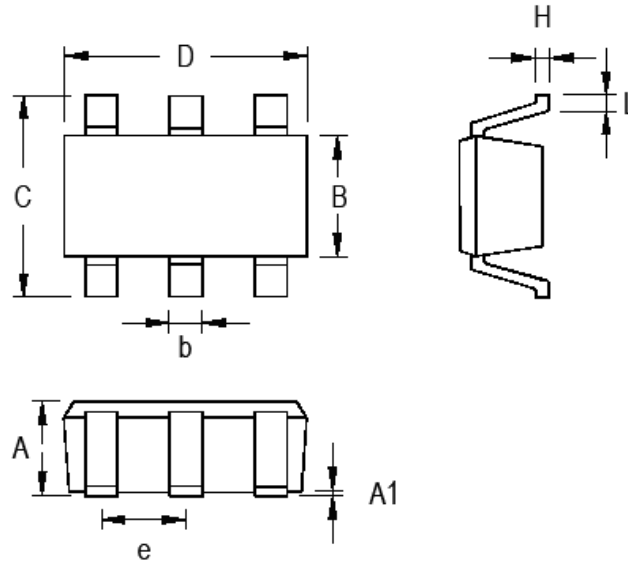

Symbol	Dimensions In Millimeters		Dimensions In Inches	
	Min	Max	Min	Max
A	0.889	1.295	0.031	0.051
A1	0.000	0.152	0.000	0.006
B	1.397	1.803	0.055	0.071
b	0.250	0.560	0.010	0.022
C	2.591	2.997	0.102	0.118
D	2.692	3.099	0.106	0.122
e	0.838	1.041	0.033	0.041
H	0.080	0.254	0.003	0.010
L	0.300	0.610	0.012	0.024