



24V Input Voltage Switch Mode Battery Charger ME4086

General Description

The ME4086 is a complete battery charger controller for one (4.2V/4.35V) or two (8.4V) or three (12.6V) cell lithium-ion battery. The ME4086 provides a small, simple and efficient solution to fast charge Li-ion battery. The ME4086 built in anti current backward function, so the application does not need the blocking diode. An external sense resistor sets the charge current with high accuracy.

An internal resistor divider and precision reference set the final float voltage to one (4.2V/4.35V) or two (8.4V) or three (12.6V) cell with $\pm 1\%$ accuracy. When the input supply is removed, the ME4086 automatically enters a low current sleep mode, dropping the battery drain current to $3\mu\text{A}$. After the charge cycle ends, if the battery voltage drops below one (4.1V/4.23V) or two (8.2V) or three (12.2V) cell, a new charge cycle will automatically begin.

Typical Applications

- Charging Docks
- Handheld Instrument TEMP
- Portable Computers

Features

- Input Supply Range:
 - One-cell: 4.7V~16V
 - Two-cell: 10V~20V
 - Three-cell: 14V~22V
- Maximum input voltage: 24V
- Built in anti current backward function
- High Efficiency Current Mode PWM Controller
- Built-in input adaptive function
- Constant Switching Frequency for Minimum Noise
- $\pm 1\%$ charge voltage accuracy
- Automatic Recharge
- Automatic Shutdown When Input Supply is Removed
- Automatic Trickle Charging of Low Voltage
- Stable with Ceramic Output Capacitor
- Battery Temperature Sensing

Package

- 8-pin ESOP8

Typical Application Circuit

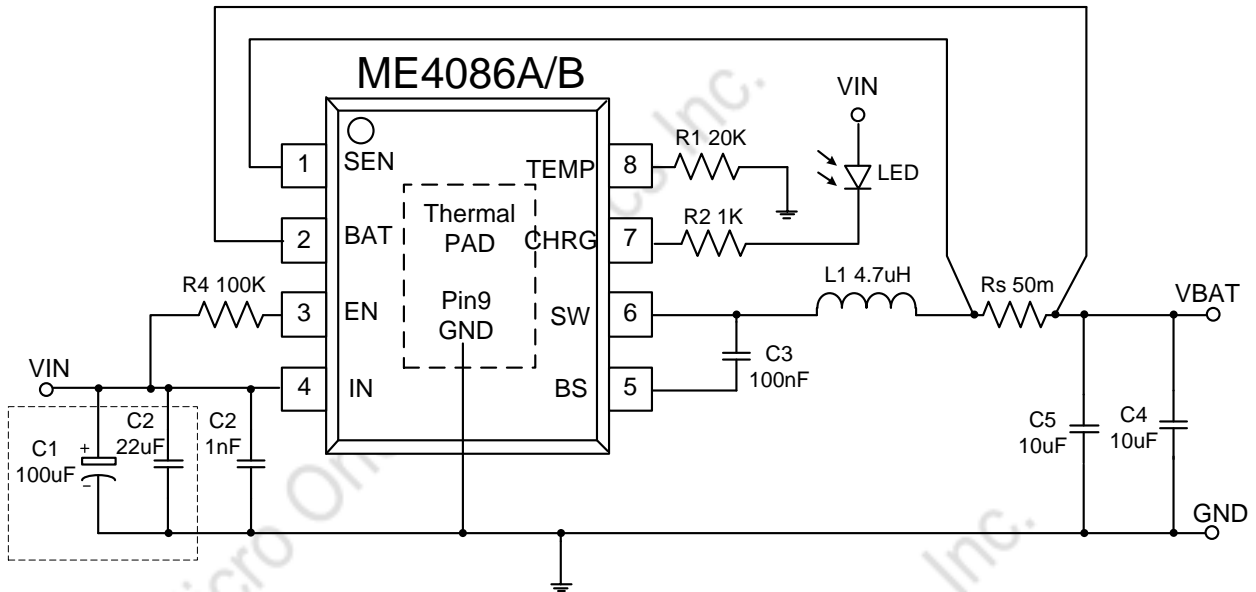

ME4086A/B Typical Application Circuit

Note: 1. The dotted part of the box is the input capacitor. When the input voltage is lower than 9V, ceramic capacitor can be selected. When the input voltage is higher than 9V, an electrolytic capacitor over 100uF should be added into the input. The larger the charging power, the larger the capacity of electrolytic capacitor.

2. For the hot-swappable application at the BAT pin, it is also necessary to add electrolytic capacitors, it is recommended to be 220uF or more.

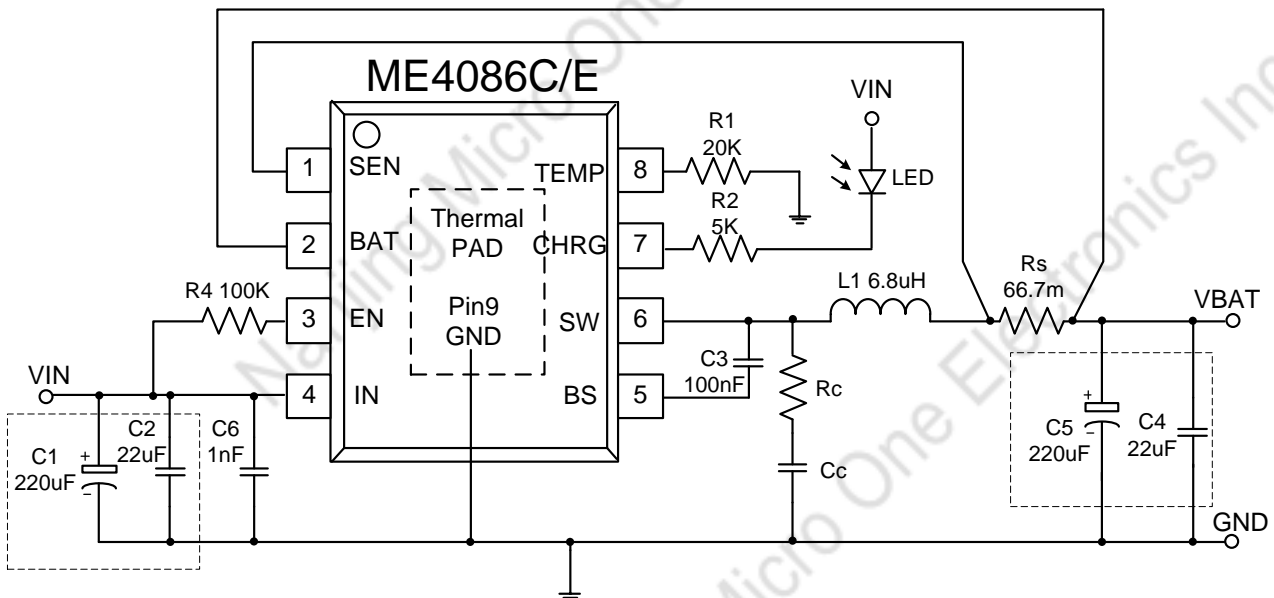

ME4086C/E Typical Application Circuit

Note: 1. The Rc and Cc value range of SW to GND, Rc: 0.5 Ω ~ 20 Ω , Cc: 1 nF ~ 100 nF.

2. For the hot-swappable application at the BAT pin, it is also necessary to add electrolytic capacitors, it is recommended to be 220uF or more.

3. In the preceding figure, Rc and Cc are optional parameters to improve system EMI characteristics, The value range of Rc and Cc: Rc: 0.5 Ω ~20 Ω , Cc: 1nF~100nF.

Selection Guide

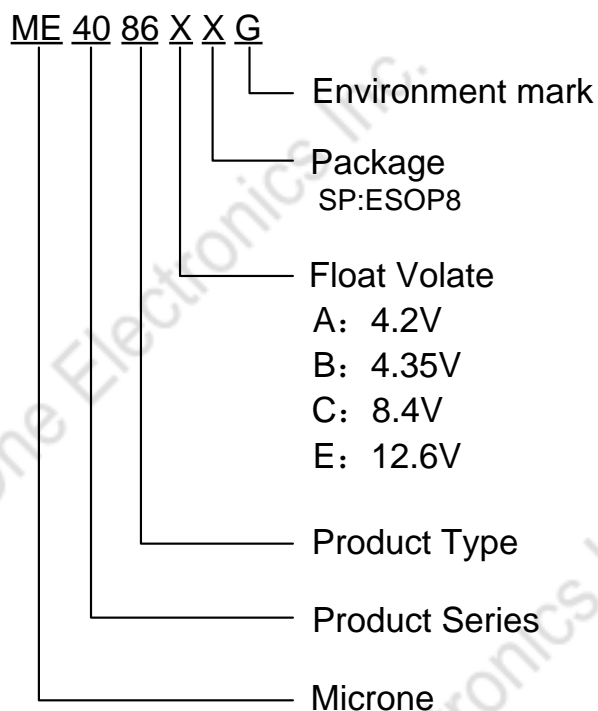

product series	product description
ME4086ASPG	$V_{\text{FLOAT}} = 4.2\text{V}$ (One-cell)
ME4086BSPG	$V_{\text{FLOAT}} = 4.35\text{V}$ (One-cell)
ME4086CSPG	$V_{\text{FLOAT}} = 8.4\text{V}$ (Two-cell)
ME4086ESPG	$V_{\text{FLOAT}} = 12.6\text{V}$ (Three-cell)

Pin Configuration

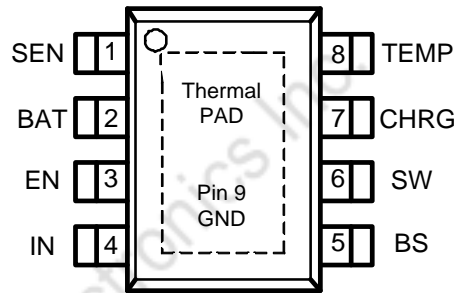

Pin Assignment

Pin Num.	Symbol	Function
1	SEN	Charge Current program. The output current is set by an external resistor according to the following formula: $I_{OUT} = 100mV/R_s$.
2	BAT	Battery access end, the capacitor should be as close to the pin as possible;
3	EN	ON/OFF Control
4	IN	Power input pin, the input capacitor should be as close to the pin as possible;
5	BS	The driver of upper MOSFET
6	SW	Switching
7	CHRG	Open drain, When the charge current drops below the End-of-Charge threshold, the N-channel MOSFET turns off. When the input supply is removed, CHRG pin becomes high impedance.
8	TEMP	Temperature sense. TEMP Thermistor Input. a negative temperature coefficient thermistor to ground, this pin senses the temperature of the battery pack, and stops the charger To disable the temperature qualification function, put a 20KΩ resistor to ground.
9	Thermal PAD	The thermal PAD is the Ground of the chip.

Block Diagram

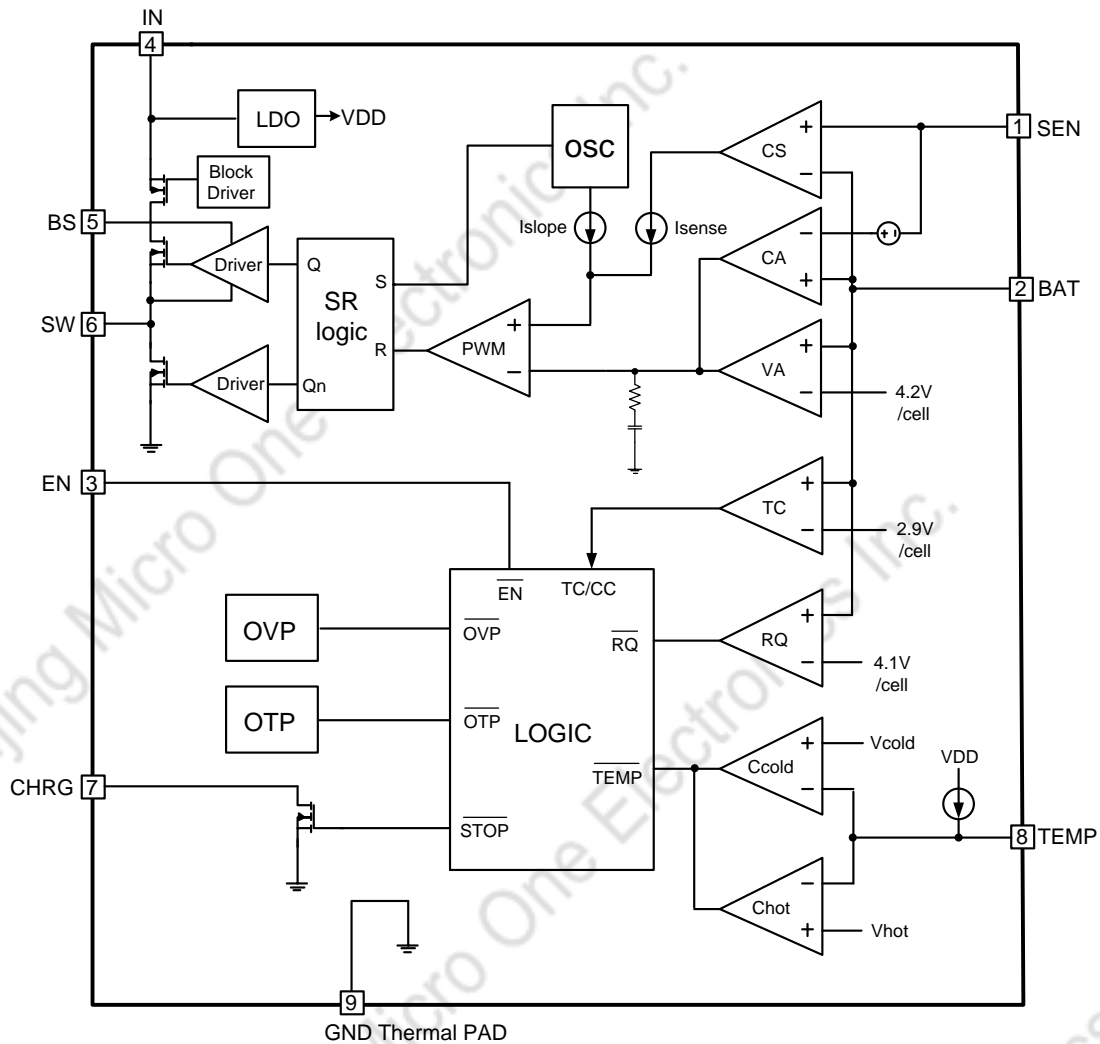

Absolute Maximum Ratings

Parameter	Rating	Unit
VIN, CHRG, BS, SW, EN Voltage	-0.3~24	V
BAT, SEN Voltage	-0.3~18	V
TEMP Voltage	-0.3~5	V
SW Pin Current	3.8	A
Thermal resistance (Junction to air) θ_{JA}	63	$^{\circ}\text{C}/\text{W}$
Internal Power Dissipation	1.98	W
Operating Ambient Temperature Range	-40~85	$^{\circ}\text{C}$
Maximum junction temperature	-40~150	$^{\circ}\text{C}$
Storage temperature :range	-55~150	$^{\circ}\text{C}$
Soldering temperature and time	+300 (Recommended 10S)	$^{\circ}\text{C}$

Caution: The absolute maximum ratings are rated values exceeding which the product could suffer physical damage.

These values must therefore not be exceeded under any conditions.

Electrical Characteristics

ME4086A/B Operating Conditions: TA=25°C, VIN=5V, Rs =0.05Ω, unless otherwise specified

Parameter	Symbol	Condition	Min	Typ	Max	Unit	
VIN	Input Voltage		4.7	5	16	V	
IIN	Input Current	BATfloat	-	1.2	-	mA	
		EN=0V, VIN=5V	-	15	-	uA	
ISLEEP		No input, BATCurrent, VBAT=4.2V	-	2.1	-	uA	
VFLOAT	Float Voltage	IBAT=2A	ME4086A	4.158	4.2	4.242	V
			ME4086B	4.307	4.35	4.393	
△VRE	Recharge battery threshold voltage	VFLOAT -VRECH	ME4086A/B	50	-	160	mV
VSNSC	CC mode	VBAT=3.5V	90	100	110	mV	
VSNST	TC mode	VBAT=2.5V	-	10	-	mV	
VTEMI	Charge Terminal Voltage		10	15	25	mV	
VRECH	Recharge Voltage		ME4086A	4.03	4.1	4.15	V
			ME4086B	4.18	4.23	4.29	
VTRCL	TC CC switch Voltage	VBAT rise	-	2.9	-	V	
VINUV	VIN under voltage protection	VIN fall	-	3.9	-	V	
	Under Voltage Hysteresis		-	300	-	mV	
VINOV	VIN over voltage protection	VIN rise	-	17	-	V	
	Over voltage Hysteresis		-	600	-	mV	
VASD	Auto shutdown	VIN-VBAT	-	30	-	mV	
VENON	EN On Voltage	EN rise	-	1.28	-	V	
VENOFF	EN Off Voltage	EN fall	-	1.25	-	V	
OTP	Over temperature protection		-	150	-	°C	
OTP_hys	The Hysteresis of OTP		-	20	-	°C	
ITEMP	TEMP Source Current	VTEMP=1V	60	68	80	uA	
VTHOT	Hot Voltage	VTEMP fall	-	0.54	-	V	
VTCOLD	Cold Voltage	VTEMP rise	-	2.4	-	V	
FOSC	Frequency		370	450	500	kHz	
DC	Max Duty		-	95	-	%	
VCHRG	CHRG Voltage	ICHRG=5mA	-	0.3	0.6	V	

ME4086C Operating Conditions: TA=25°C, VIN=15V, Rs =0.0667Ω, unless otherwise specified

Parameter	Symbol	Condition	Min	Typ	Max	Unit
VIN	Input Voltage		10	-	22	V
IIN	Input Current	BATfloat	-	2	-	mA
		EN=0V, VIN=12V	-	25	-	uA
ISLEEP		No input, BATCurrent, VBAT=8.4V	-	4	-	uA
VFLOAT	Float Voltage	IBAT=1.5A	8.316	8.4	8.484	V
VSNSC	CC mode	VBAT=7.5V	90	100	110	mV
VSNST	TC mode	VBAT=5V	-	10	-	mV
VTEMI	Charge Terminal Voltage		-	18	-	mV
VRECH	Recharge Voltage		8.05	8.2	8.30	V
ΔVRE	Recharge battery threshold voltage	VFLOAT -VRECH	120	-	330	mV
VTRCL	TC CC switch Voltage	VBAT rise	-	6.0	-	V
VINUV	VIN under voltage protection	VIN fall	-	3.9	-	V
	Under Voltage Hysteresis		-	300	-	mV
VINOV	VIN over voltage protection	VIN rise	-	22	-	V
	Over voltage Hysteresis		-	800	-	mV
VASD	Auto shutdown	VIN-VBAT	-	20	-	mV
VENON	EN On Voltage	EN rise	-	1.24	-	V
VENOFF	EN Off Voltage	EN fall	-	1.12	-	V
OTP	Over temperature protection		-	150	-	°C
OTP_hys	The Hysteresis of OTP		-	20	-	°C
ITEMP	TEMP Source Current	VTEMP=1V	60	68	80	uA
VTHOT	Hot Voltage	VTEMP fall	-	0.534	-	V
VTcold	Cold Voltage	VTEMP rise	-	2.4	-	V
FOSC	Frequency		370	450	500	kHz
DC	Max Duty		-	92	-	%
VCHRG	CHRG Voltage	ICHRG=5mA	-	0.3	0.6	V

ME4086E Operating Conditions: TA=25°C, VIN=15V, Rs =0.0667Ω, unless otherwise specified

Parameter	Symbol	Condition	Min	Typ	Max	Unit	
VIN	Input Voltage		14	-	22	V	
IIN	Input Current	BATfloat	-	1.2	-	mA	
		EN=0V, VIN=15V	-	25	-	uA	
ISLEEP		No input, BATCurrent, VBAT=12.6V	-	10	-	uA	
VFLOAT	Float Voltage	IBAT=1.5A	ME4086E	12.474	12.6	12.726	V
△VRE	Recharge battery threshold voltage	VFLOAT -VRECH	ME4086E	150	-	450	mV
VSNSC	CC mode	VBAT=11.8V	90	100	110	mV	
VSNST	TC mode	VBAT=8V	-	10	-	mV	
VTEMI	Charge Terminal Voltage		-	18	-	mV	
VRECH	Recharge Voltage		ME4086E	12.09	12.2	12.5	V
VTRCL	TC CC switch Voltage	VBAT rise	-	8.5	-	V	
VINUV	VIN under voltage protection	VIN fall	-	3.9	-	V	
	Under Voltage Hysteresis		-	300	-	mV	
VINOV	VIN over voltage protection	VIN rise	-	23	-	V	
	Over voltage Hysteresis		-	800	-	mV	
VASD	Auto shutdown	VIN-VBAT	-	20	-	mV	
VENON	EN On Voltage	EN rise	-	1.24	-	V	
VENOFF	EN Off Voltage	EN fall	-	1.12	-	V	
OTP	Over temperature protection		-	150	-	°C	
OTP_hys	The Hysteresis of OTP		-	20	-	°C	
ITEMP	TEMP Source Current	VTEMP=1V	60	68	80	uA	
VTHOT	Hot Voltage	VTEMP fall	-	0.534	-	V	
VTcold	Cold Voltage	VTEMP rise	-	2.4	-	V	
FOSC	Frequency		400	480	530	kHz	
DC	Max Duty		-	92	-	%	
VCHRG	CHRG Voltage	ICHRG=5mA	-	0.3	0.6	V	

Description of the Principle

The ME4086 is a constant current, constant voltage Li-Ion battery charger controller that uses a current mode PWM step-down (buck) switching architecture. The charge current is set by an external sense resistor (R_s) across the SEN and BAT pins. The final battery float voltage is internally set to one (4.2V/4.35V) or two (8.4V) or three (12.6V) cell. For batteries like lithium-ion that require accurate final float voltage, the internal reference, voltage amplifier and the resistor divider provide regulation with high accuracy. A charge cycle begins when the voltage at the VIN pin is greater than the battery voltage 100mV. At the beginning of the charge cycle, if the battery voltage is less than the trickle charge threshold, the charger goes into trickle charge mode. The trickle charge current is internally set to 10% of the full-scale current. When the battery voltage exceeds the trickle charge threshold, the charger goes into the full-scale constant current charge mode. In constant current mode, the charge current is set by the external sense resistor R_s and an internal 100mV reference; $I_{OUT} = 100\text{mV}/R_s$:

When the battery voltage approaches the programmed float voltage, the charge current will start to decrease. When the current drops to 15% of the full-scale charge current, an internal comparator turns off the internal pull-down N-channel MOSFET at the CHRG pin to indicate a end-of-charge condition and then the charge cycle is terminated and the CHRG pin is forced high impedance. To restart the charge cycle, remove and reapply the input voltage or momentarily shut the charger down. Also, a new charge cycle will begin if the battery voltage drops below the recharge threshold voltage. When the input voltage is present, the charger can be shut down. When the input voltage is not present, the charger goes into sleep mode. This will greatly reduce the current drain on the battery and increase the standby time. A TEMP (negative temperature coefficient) thermistor can be connected from the TEMP pin to ground for battery temperature qualification. To disable the temperature qualification function, put a 20K Ω resistor to ground.

Functional Description

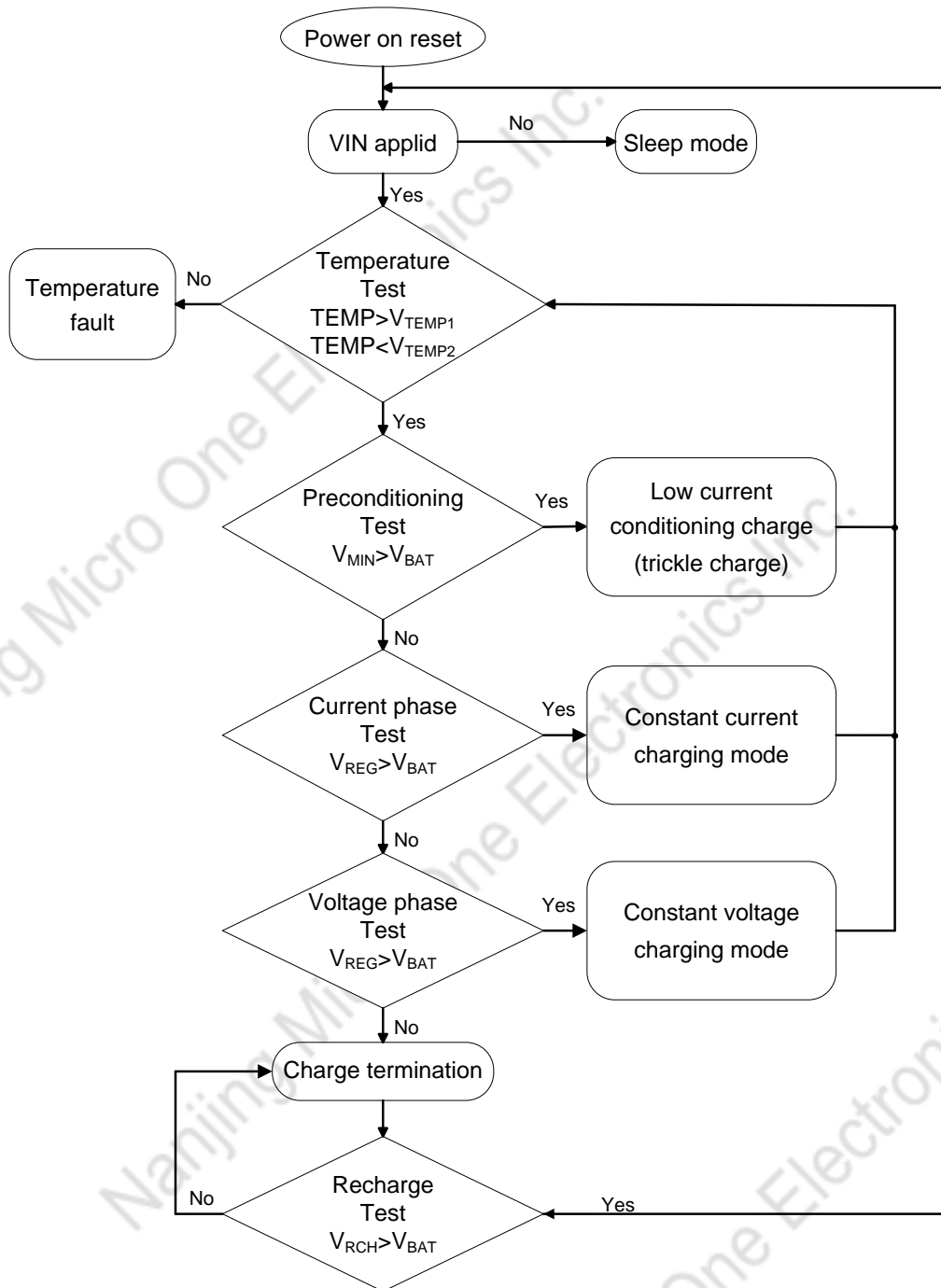

Fig. 1: Operation Flow Chart

Qualification and Precharge

The ME4086 suspends charge if the battery temperature is outside the VTEMP1 to VTEMP2 range and suspends charge until the battery temperature is within the allowed range. The ME4086 also checks the battery voltage. If the battery voltage is below the precharge threshold $V(\min)$, the ME4086 uses precharge to condition the battery. The conditioning charge rate $I(\text{PRECHG})$ is set at approximately 10% of the regulation current. See Fig.2 for a typical charge-profile.

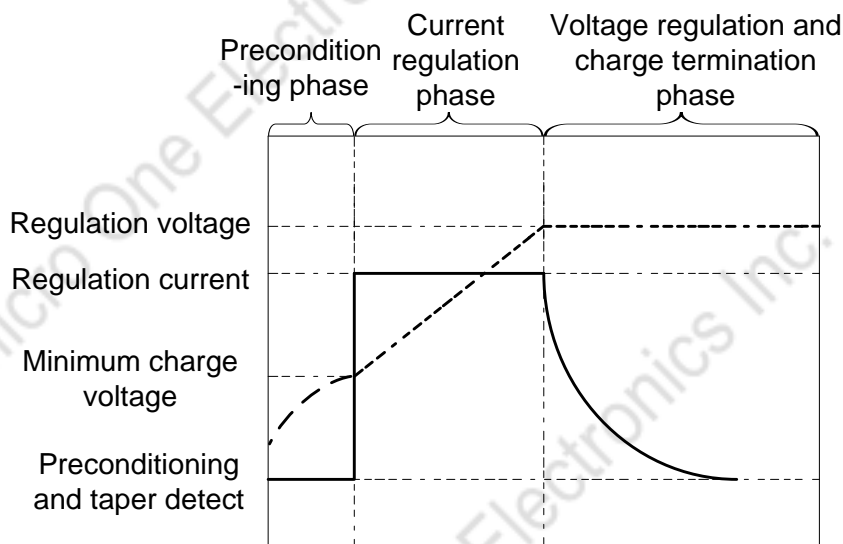

Fig. 2: Typical Charge Profile

Charge Termination Recharge

The ME4086 monitors the charging current during the voltage-regulation phase. The ME4086 declares a done condition and terminates charge when the current drops to the charge termination threshold. A new charge cycle begins when the battery voltage falls below 4.1V/4.23V/8.2V/12.2V (4.2V/4.35V/8.4V/12.6V product).

Battery Temperature Monitoring

A negative temperature coefficient (NTC) thermistor located close to the battery pack can be used to monitor battery temperature and will not allow charging unless the battery temperature is within an acceptable range. Connect a thermistor from the TEMP pin to ground. The formulas for calculating resistance selection are as follows.

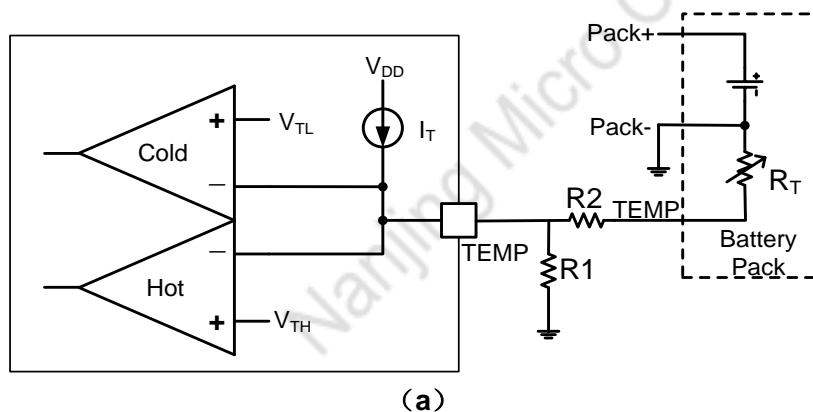

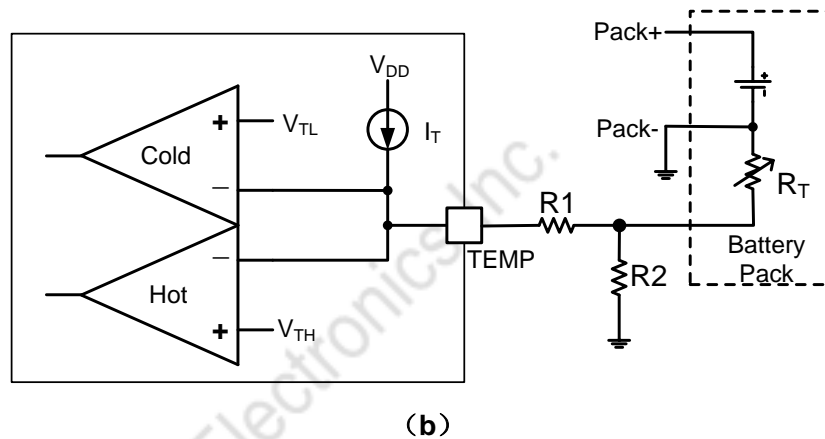

Fig 3: Thermistor Selection of Corresponding Circuits

The relationship of R1, R2 and RTH, RTL as follows:

$$(a) \quad \frac{1}{R_{TH} + R_2} + \frac{1}{R_1} = \frac{I_T}{V_{TH}} \qquad \frac{1}{R_{TL} + R_2} + \frac{1}{R_1} = \frac{I_T}{V_{TL}}$$

$$(b) \quad R_1 + \frac{R_2 \times R_{TH}}{R_2 + R_{TH}} = \frac{V_{TH}}{I_T} \qquad R_1 + \frac{R_2 \times R_{TL}}{R_2 + R_{TL}} = \frac{V_{TL}}{I_T}$$

RTH and RTL are the resistance values of thermistors at high and low temperatures respectively. The corresponding resistance values can be found according to the required temperature. VTH, VTL, IT are the design values, where VTH = 0.52V, VTL = 2.26V, IT = 68uA. The resistance values corresponding to R1 and R2 can be calculated by bringing these values into the calculation formula above.

To disable the temperature qualification function, put a 20KΩ resistor to ground.

Charge Status Indication

The ME4086 reports the status of the charge on the CHRG pin. The following Table 1 summarized the operation of the CHRG pin. The CHRG pin can be used to drive a chip LED.

Table 1

Condition	CHRG pin
Battery conditioning and charging	Low
Charge complete(done)	Hi-Z
Temperature fault or sleep mode	Hi-Z

Automatic Shutdown Voltage (ASD)

When the difference between input voltage and battery voltage VBAT is less than 20 mV, IC will enter automatic shutdown mode.

Trickle Charge

At the beginning of a charge cycle, if the battery voltage is below the trickle charge threshold, the charger goes into trickle charge mode with the charge current reduced to 10% of the full-scale current.

Shutdown

The ME4086 can be shut down by pulling the EN pin to ground. In shutdown, the output of the CHRG pin is high impedance and the quiescent current remains at 25 μ A.

Input and Output Capacitors

Since the input capacitor is assumed to absorb all input switching ripple current in the converter, it must have an adequate ripple current rating. Worst-case RMS ripple current is approximately one-half of output charge current. Actual capacitance value is not critical. Solid tantalum capacitors have a high ripple current rating in a relatively small surface mount package, but caution must be used when tantalum capacitors are used for input bypass. High input surge currents can be created when the adapter is hot-plugged to the charger. When the input voltage exceeds 9V, the electrolytic capacitor should be added to absorb the peak voltage. The larger the charging power is, the larger the electrolytic capacitor capacity will be. Normally, the electrolytic capacitor should be larger than 100 μ F. Selecting the highest possible voltage rating on the capacitor will minimize problems. Consult with the manufacturer before use.

The selection of output capacitor C_{OUT} is primarily determined by the ESR required to minimize ripple voltage and load step transients. The output ripple ΔV_{OUT} is approximately bounded by:

$$\Delta V_{OUT} \leq \Delta I_L \left(ESR + \frac{1}{8f_{OSC} C_{OUT}} \right)$$

Since ΔI_L increases with input voltage, the output ripple is highest at maximum input voltage. Typically, once the ESR requirement is satisfied, the capacitance is adequate for filtering and has the necessary RMS current rating. Switching ripple current splits between the battery and the output capacitor depending on the ESR of the output capacitor and the battery impedance. EMI considerations usually make it desirable to minimize ripple current in the battery leads. Ferrite beads or an inductor may be added to increase battery impedance at the 1.1MHz switching frequency. If the ESR of the output capacitor is 0.2 Ω and the battery impedance is raised to 4 Ω with a bead or inductor, only 5% of the current ripple will flow in the battery.

Typical Performance Characteristics

电感电流 (CC) 和开关波形

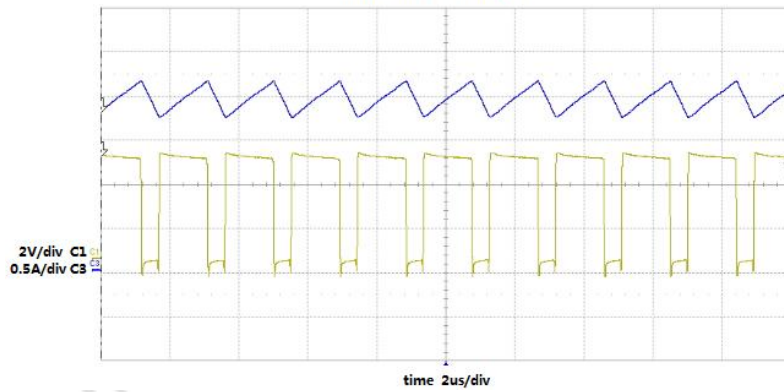

电感电流 (TC) 和开关波形

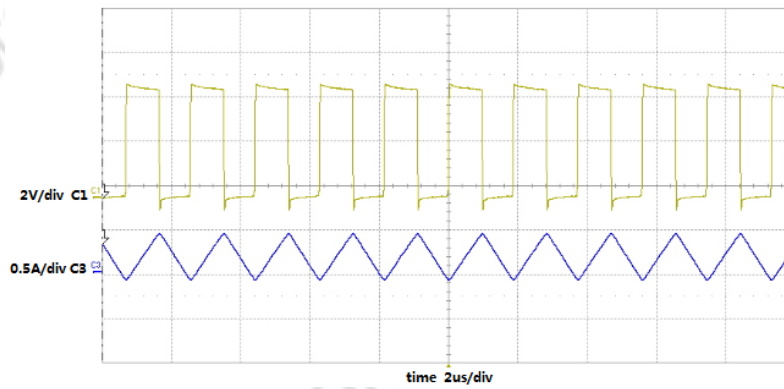

Isleep vs. VBAT

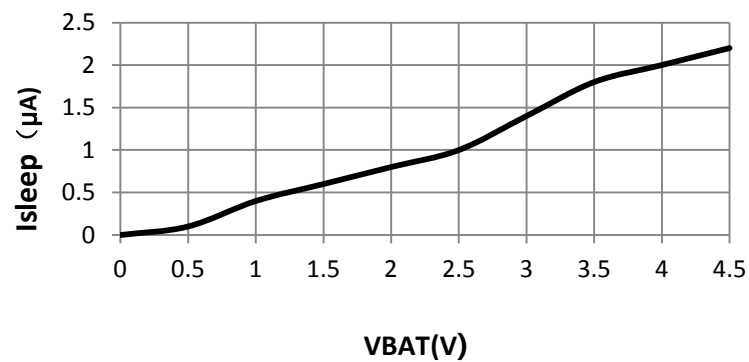

Vsense vs. Temperature

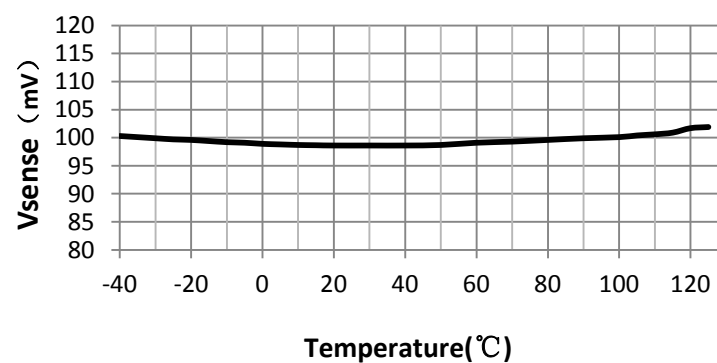

Package Quantity

Package Type	Minimum Packing QTY	UNITS	Small Box	Large BOX
ESOP8	3000	Tape & Reel	6K	48K

Nanjing Micro One Electronics Inc.

Nanjing Micro One Electronics Inc.

Nanjing Micro One Electronics Inc.

Packaging Information:

- Packaging Type: ESOP8

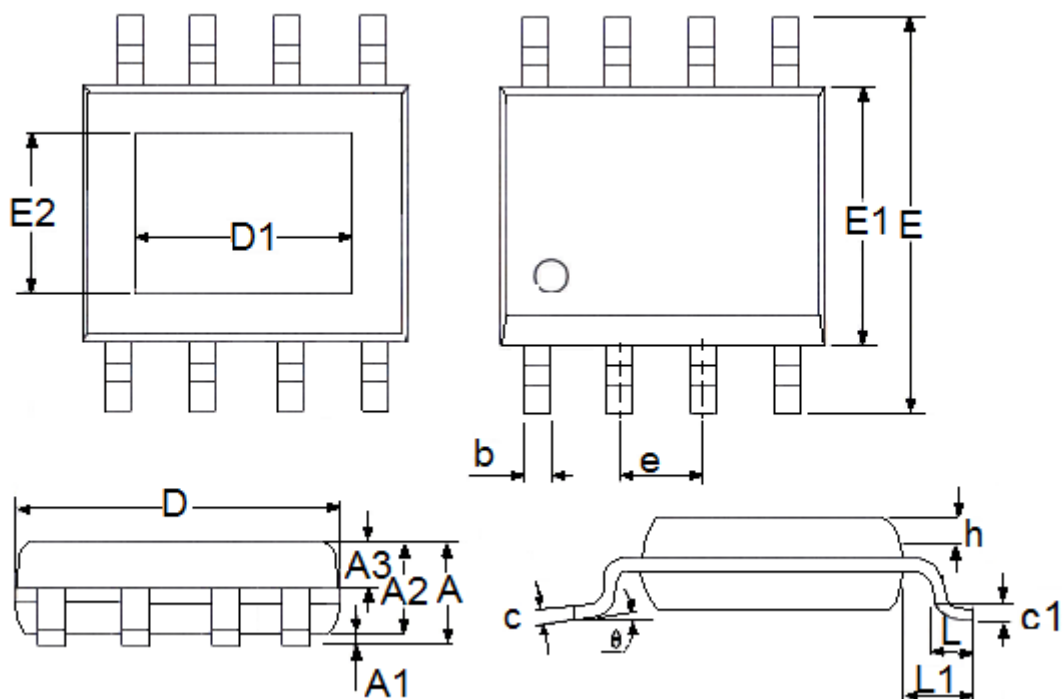

DIM	Millimeters		Inches	
	Min	Max	Min	Max
A	1.3	1.75	0.0512	0.0689
A1	0	0.2	0.0000	0.0079
A2	1.25	1.65	0.0492	0.0650
A3	0.5	0.7	0.0197	0.0276
b	0.33	0.51	0.0130	0.0201
c	0.17	0.25	0.0067	0.0098
D	4.7	5.1	0.1850	0.2008
E	5.8	6.2	0.2283	0.2441
E1	3.8	4	0.1496	0.1575
e	1.27(TYP)		0.05(TYP)	
h	0.25	0.5	0.0098	0.0197
L	0.4	1.27	0.0157	0.0500
L1	1.04(TYP)		0.0409(TYP)	
θ	0	8°	0.0000	8°
c1	0.25(TYP)		0.0098(TYP)	
D1	3.1(TYP)		0.122(TYP)	
E2	2.21(TYP)		0.087(TYP)	

- The contents of this document will be updated with the product's improvement without prior notice. Please consult our sales staff before using this document to ensure that you are using the latest version.
- The application circuit examples described in this document are only used to indicate the representative use of the product and do not guarantee the design of mass production.
- Please use this product within the limits stated in this document. We will not be responsible for any damage caused by improper use.
- The products described in this document are not allowed to be used in equipment or devices that affect the human body without the written permission of our company, including but not limited to: health equipment, medical equipment, disaster prevention equipment, fuel control equipment, automobile equipment, aviation equipment and vehicle equipment.
- Although our company has always been committed to improving product quality and reliability, semiconductor products have a certain probability of malfunction or wrong work. To prevent personal injury or property damage caused by such accidents, please pay full attention to safety design, for example: Alternate design, fire protection design, and prevention of wrong action design.
- When exporting this product or this document overseas, you should abide by applicable import and export control laws.
- Copying or reprinting part or all of this document in any form without the permission of our company is strictly prohibited.